

ZONE		REV	DESCRIPTION	REVISION HISTORY		
A		A	RELEASED PER ECN 1080943	DATE	DWN	CHK

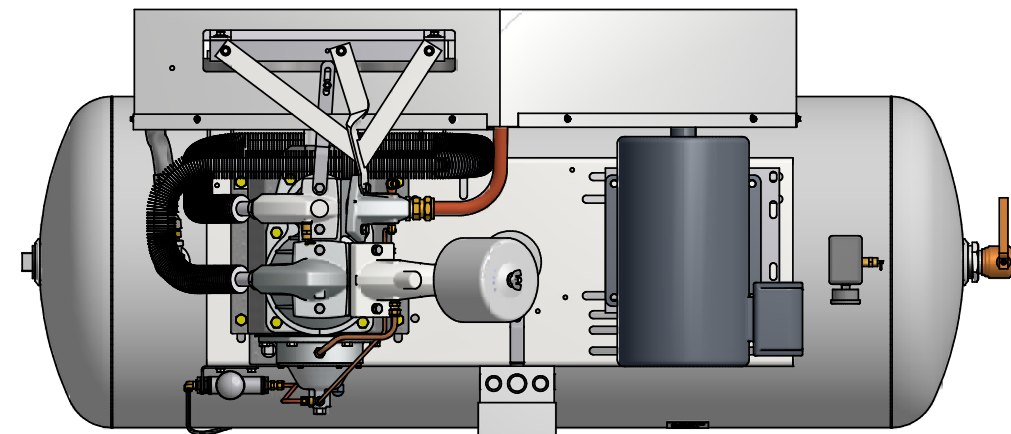

STARTER (OPTIONAL)

COMPRESSOR: R40A

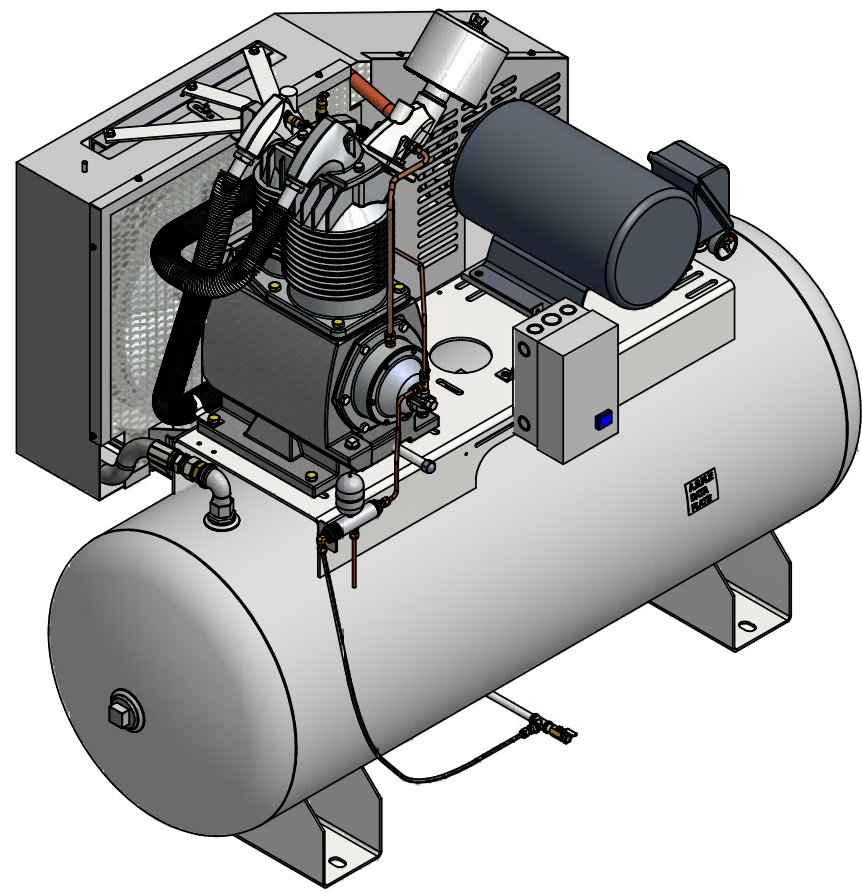
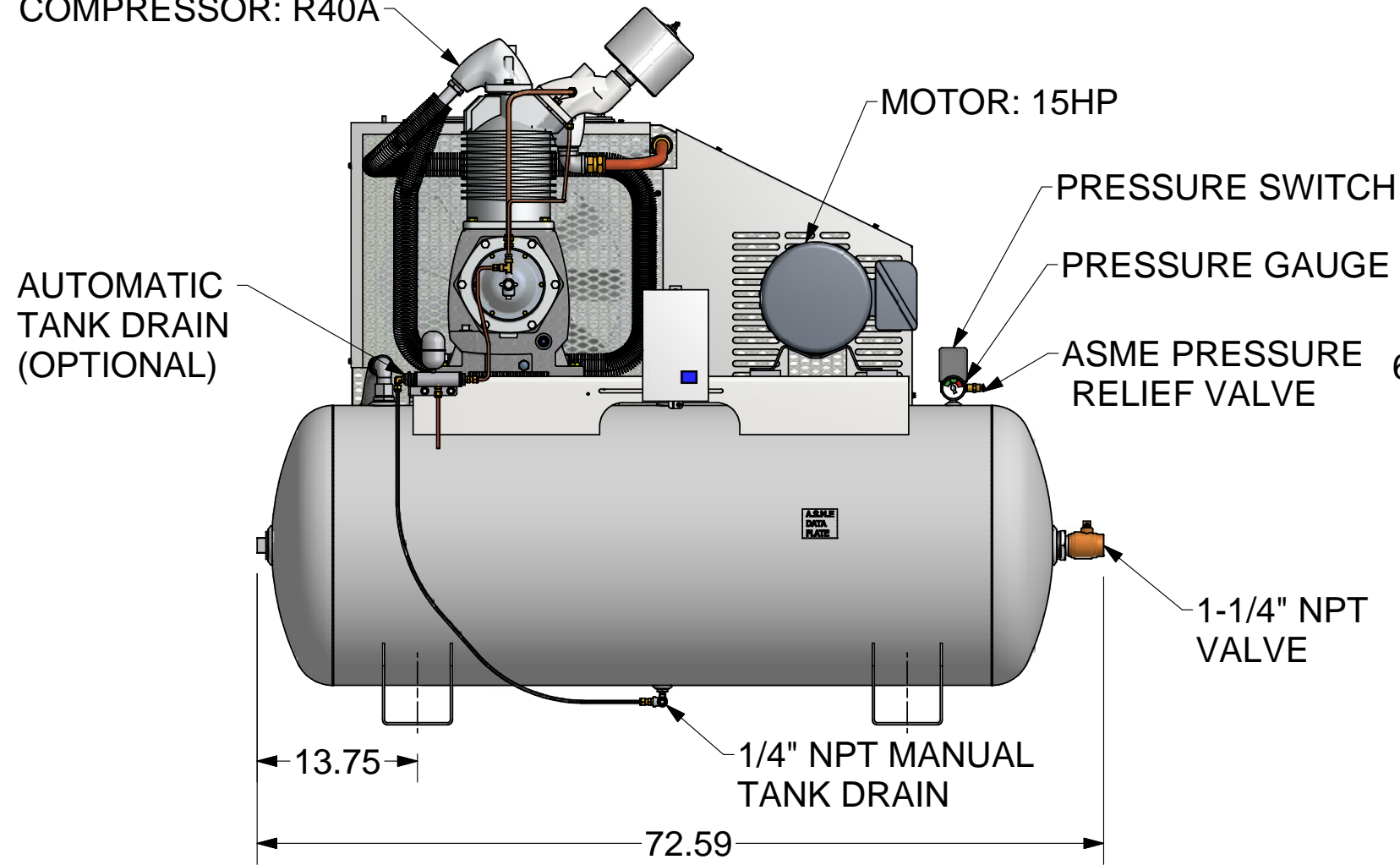

MOTOR: 15HP

PRESSURE SWITCH

PRESSURE GAUGE

ASME PRESSURE RELIEF VALVE

AUTOMATIC TANK DRAIN (OPTIONAL)

1-1/4" NPT VALVE

1/4" NPT MANUAL TANK DRAIN

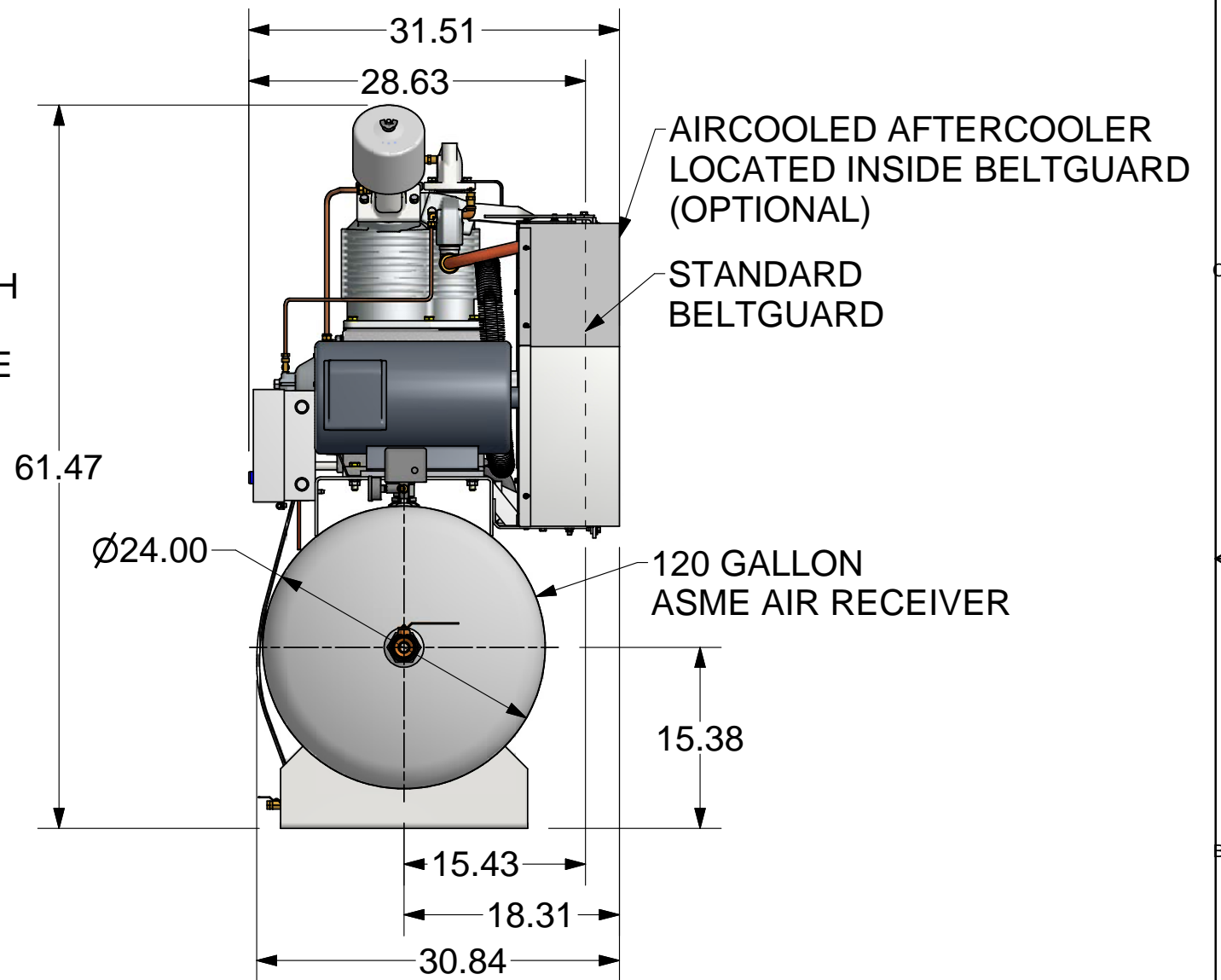

AIRCOOLED AFTERCOOLER LOCATED INSIDE BELTGUARD (OPTIONAL)

STANDARD BELTGUARD

120 GALLON ASME AIR RECEIVER

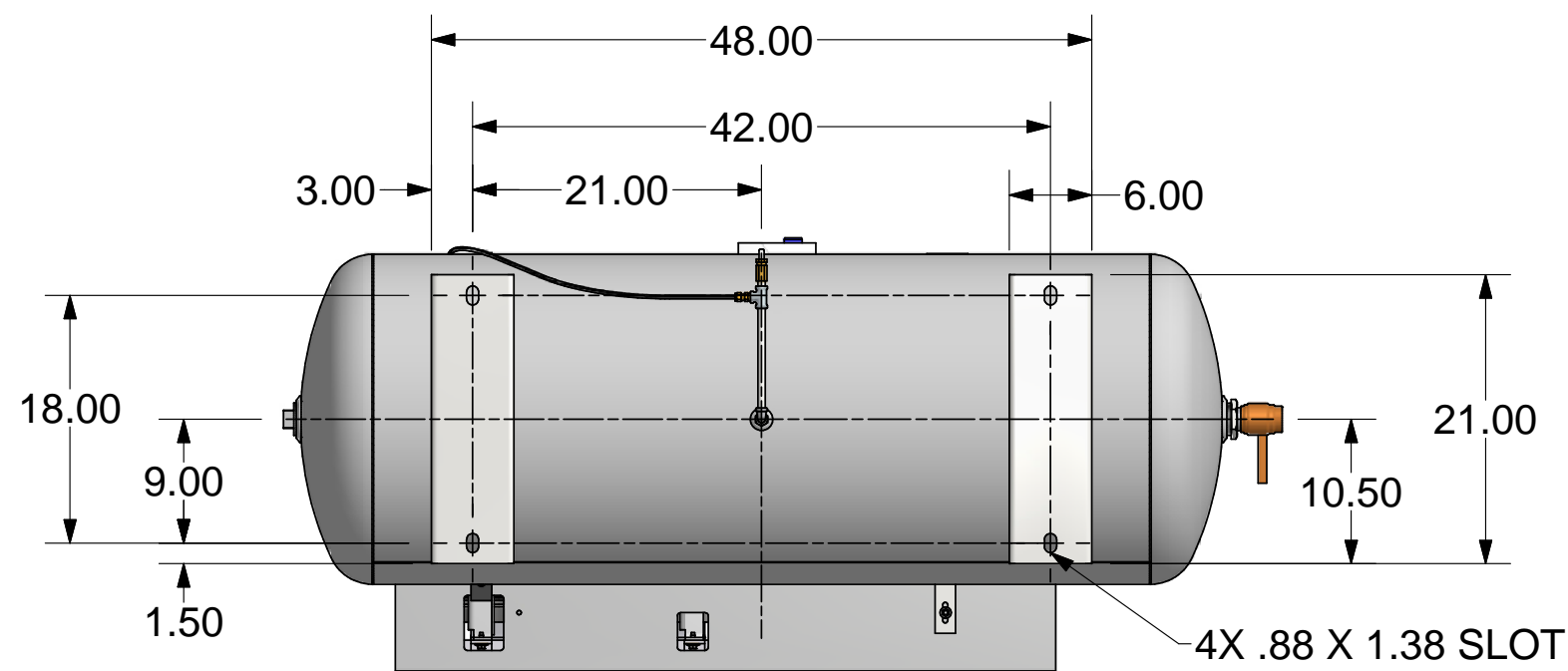

4X .88 X 1.38 SLOT

- NOTES:
- DO NOT SCALE DRAWING.
  - SPECIFICATIONS AND DIMENSIONS ARE SUBJECT TO CHANGE WITHOUT NOTICE OR OBLIGATION.
  - ALL DIMENSIONS IN INCHES.
  - ADD 1.00" TO HEIGHT FOR VIBRATION ISOLATION OPTION.

FINISH OF CHAMFERS AND FILLETS TO CONFORM TO ROUGHEST ADJACENT AREA. SURFACE ROUGHNESS MAXIMUM PER ASME B46.1. FULL THREAD DEPTHS ARE MINIMUM.  UNLESS OTHERWISE SPECIFIED DIMENSIONS ARE IN INCHES TOL. ON DECIMALS: .X = ± .05 TOL. ON DECIMALS: .XX = ± .02 TOL. ON DECIMALS: .XXX = ± AS SPECIFIED TOL. ON ANGLES: ± 0°-30'	CONFIDENTIAL - THE INFORMATION CONTAINED IN THIS DOCUMENT IS THE PROPERTY OF GARDNER DENVER, INC. IT IS NOT FOR PUBLIC DISCLOSURE. POSSESSION OF THE INFORMATION DOES NOT CONVEY ANY RIGHT TO LOAN, SELL OR DISCLOSE THE INFORMATION. UNAUTHORIZED REPRODUCTION OR USE OF THE INFORMATION IS PROHIBITED. THIS DOCUMENT IS TO BE RETURNED TO GARDNER DENVER, INC. UPON THE COMPLETION OF THE PURPOSE FOR WHICH IT IS LOANED OR UPON REQUEST.	
	DIMENSIONING AND TOLERANCING PER ASME Y14.5-2009 THREADS PER ASME B1.1 GAGING SYSTEM 21 U.O.S., ANSI B1.20.1 & B1.20.3	
THIRD ANGLE PROJECTION	Gardner Denver Inc. Quincy, IL.	HEAT TREATMENT ENG. REF:
DWN BY KWT 6/6/2014 CKD BY DA 6/6/2014	TITLE HRA15-12 OUTLINE-BARE UNIT	REV DA 6/6/2014 339CAS800
SCALE 1/9	SHEET 1 OF 1	REV A