

**CHAMPION**

**R-SERIES**

Air Compressors & Units

# R-40 PARTS LIST MANUAL



**WARNING**

REFER TO THE R-SERIES OPERATION & SERVICE MANUAL FOR IMPORTANT SAFETY INFORMATION. READ, UNDERSTAND AND RETAIN ALL INSTRUCTIONS BEFORE OPERATING OR SERVICING THIS EQUIPMENT TO PREVENT INJURY OR EQUIPMENT DAMAGE.

**MAINTAIN COMPRESSOR RELIABILITY AND PERFORMANCE WITH  
GENUINE CHAMPION® COMPRESSOR  
PARTS AND SUPPORT SERVICES**

Champion® Compressor genuine parts, manufactured to design tolerances, are developed for optimum dependability – specifically for Champion compressor systems. Design and material innovations are the result of years of experience with hundreds of different compressor applications. Reliability in materials and quality assurance are incorporated in our genuine replacement parts.

Your authorized Champion Compressor distributor offers all the backup you'll need. A worldwide network of authorized distributors provides the finest product support in the air compressor industry.

Your authorized distributor can support your Champion air compressor with these services:

1. Trained parts specialists to assist you in selecting the correct replacement parts.
2. A full line of factory tested CHAMPLUB™ compressor lubricants specifically formulated for use in Champion compressors.
3. Repair and maintenance kits designed with the necessary parts to simplify servicing your compressor.

Authorized distributor service technicians are factory trained and skilled in compressor maintenance and repair. They are ready to respond and assist you by providing fast, expert maintenance and repair services.

**To Contact Champion or locate your local distributor:**

**Visit: [www.championpneumatic.com](http://www.championpneumatic.com)**

Or

Call: (888)436-5499

**INSTRUCTIONS FOR ORDERING REPAIR PARTS**

When ordering parts, specify Compressor MODEL, HORSEPOWER and SERIAL NUMBER (see nameplate on unit). All orders for Parts should be placed with the nearest authorized distributor.

Order by part number and description. Reference numbers are for your convenience only.

# Table of Contents

Section 1 – General ..... 5

    Dimensions..... 5

    Specifications ..... 5

    Performance ..... 5

Section 2 – Compressor ..... 6

    Crankcase Group..... 6

    Crankshaft Group..... 7

    Centrifugal Unloader Group..... 8

    Piston/Rod Group – Low Pressure ..... 10

    Piston/Rod Group – High Pressure ..... 12

    Cylinder Group – Standard..... 14

    Cylinder Group – with Head Unloaders (optional) ..... 16

    Tubing and Control Group – Standard ..... 18

    Tubing and Control Group – with Head Unloaders (optional)..... 20

    High Temperature Switch (optional) ..... 22

    Filter Maintenance Indicator (optional)..... 22

    Low Oil Shutdown Control (optional) ..... 23

Section 3 – Electric Packages ..... 24

    Horizontal Package – Simplex ..... 24

    Horizontal Package – Duplex (California Code) ..... 26

    Electric Motor List ..... 28

    Tank Drain – Manual ..... 29

    Tank Drain – Electric (optional)..... 30

    Control Group – Simplex Start/Stop ..... 31

    Control Group – Simplex Dual Control (optional)..... 32

## Table of Contents

Control Group – Duplex Start/Stop.....	33
Control Group – Duplex Dual Control (optional) .....	34
Power Transmission .....	35
Belt Guard – Standard.....	36
Belt Guard – with Aftercooler (optional) .....	37
Discharge Piping – Simplex Horizontal, Standard .....	38
Discharge Piping – Simplex Horizontal, with Aftercooler (optional) .....	39
Discharge Piping – Duplex Horizontal, Standard .....	40
Discharge Piping – Duplex Horizontal, with Aftercooler (optional).....	41
Notes.....	42

## Section 1 – General

### Dimensions

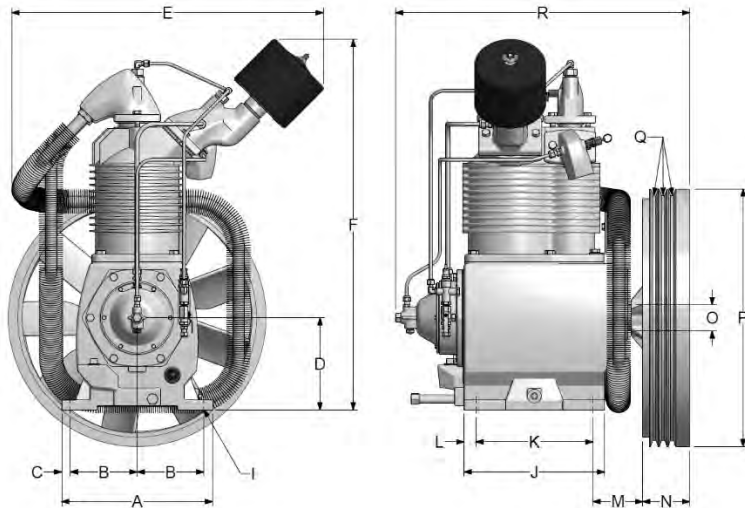

C422-D  
Ref Drawing

Item		R10D
A	Base-Width	12-7/8"
B	Bolt Down-Width	5-11/16"
C	Bolt Down to Edge	3/4"
D	Base to Crank Ctr	7-15/16"
E	Overall Width	25-1/2"
F	Overall Height	32"
I	Bolt Down Hole Dia.	9/16"
J	Base-Depth	12"
K	Bolt Down Depth	10"
L	Bolt Down to Edge	1"
M	Bolt Hole to Wheel (Max.)	5-3/4"
N	Flywheel Width	3-1/2"
O	Crank Diameter	2-1/4"
P	Flywheel Diameter	22"
Q	Flywheel Grooves	3VB
R	Overall Depth	26"

- H.P. Exhaust Opening: 1" tubing
- Flywheel Rotation – Clockwise when viewed from front, flywheel to rear.

### Specifications

BORE & STROKE (INCHES)	NO. OF CYLINDERS	OIL CAP. (QTS.)	WEIGHT (LBS)	PRESSURE (PSIG)	CU FT./REV.	MIN./MAX. RPM
6-1/4 & 3-1/4 x 4-1/2	2	4	336	175	.0800	425/1000

### Performance

OUTPUT PRESS. PSIG	MOTOR H.P.	PUMP RPM	DISPL. CFM	COOLING AIR FLOW CFM	HEAT REJECTION BTU/HR	APPROX. PULLEY O.D. INCHES
125	15	919	73.52	1336	33,600	11.40
175	15	782	62.56	1137	33,600	9.75

All data is based on 1800 RPM electric motors as a power source.

Pulley Dia. (approx.) =  $\frac{\text{Compressor RPM} \times \text{Flywheel Dia.}}{\text{Motor or Engine RPM}}$

## Section 2 – Compressor

### Crankcase Group

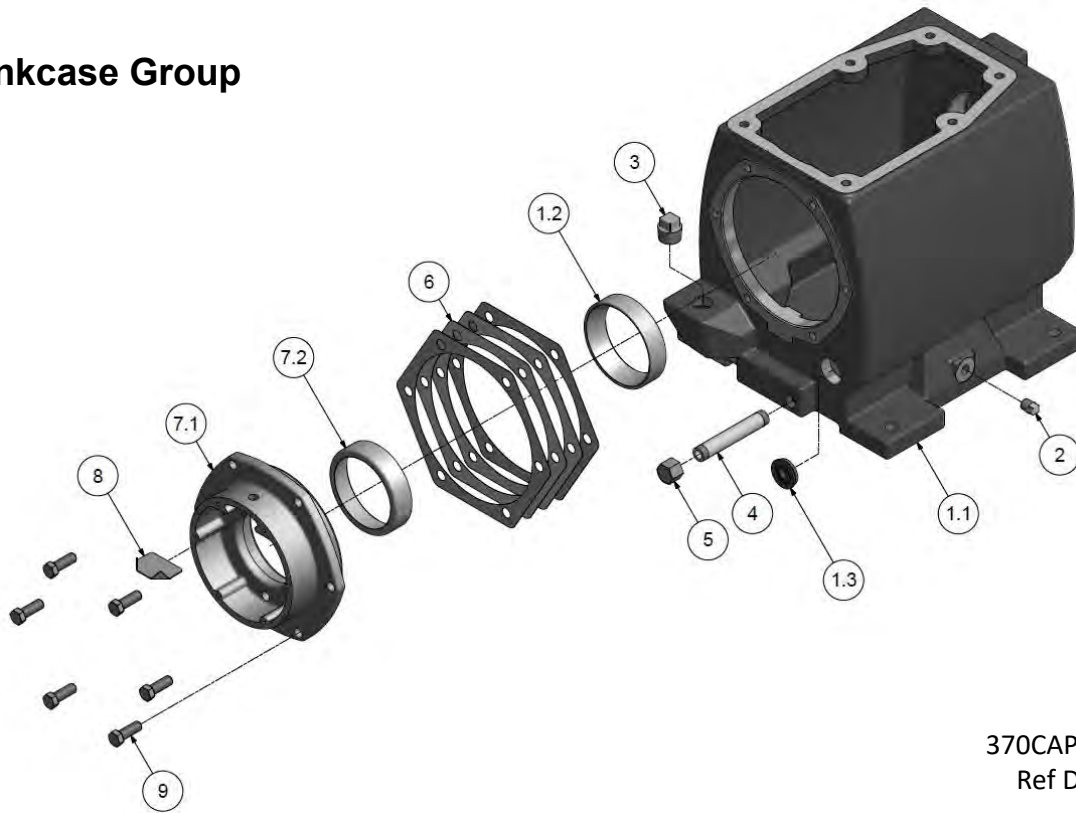

370CAP810-01  
Ref Drawing

#### CRANKCASE GROUP

#### 303CAP013

Item	Part Number	Description	Qty
1.1	M1453	CRANKCASE	1
1.2	P03431A1*	MAIN BEARING, CUP	1
1.3	RE714	OIL LEVEL GAUGE	1
2	64AA5	PLUG	1
3	64A5	PLUG	1
4	M492	NIPPLE	1
5	M461	CAP	1
6	M1398*	GASKET, 0.032	1
6	M1399*	GASKET, 0.015	1
6	M1400*	GASKET, 0.010	1
6	M1401*	GASKET, 0.006	1
7.1	P12274C	GOVERNOR HOUSING	1
7.2	P03431A1*	MAIN BEARING, CUP	1
8	P12381A	PLATE, GOVERNOR BAFFLE	1
9	M2345	SCREW (torque @ 550 in-lbs)	6

\*not sold separately – see repair parts

#### REPAIR PARTS

Item	Part Number	Description	Qty
1.2,7.2	Z6506	MAIN BEARING	2
6	Z775	GOVERNOR HOUSING GASKET SET	1
-	Z10888	COMPRESSOR GASKET SET (excludes valve gaskets)	1

## Crankshaft Group

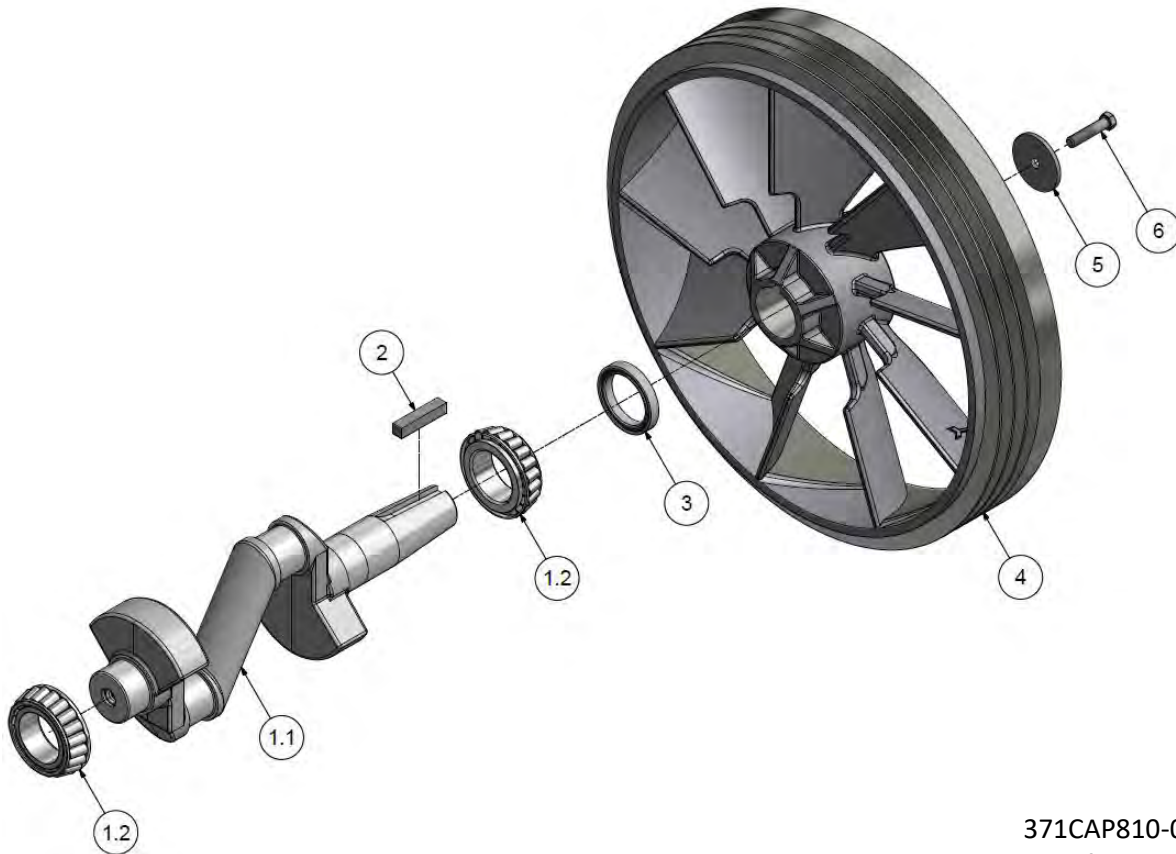

371CAP810-01  
Ref Drawing

### CRANKSHAFT GROUP

303CAP004

Item	Part Number	Description	Qty
1.1	M1458	CRANKSHAFT	1
1.2	P03431A2*	MAIN BEARING, CONE & ROLLER	2
2	M1506	KEY	1
3	P03433A	OIL SEAL	1
4	P05723C	FLYWHEEL	1
5	M1394	WASHER	1
6	M2265	SCREW (torque @ 600 in-lbs)	1

\*not sold separately – see repair parts

### REPAIR PARTS

Item	Part Number	Description	Qty
1.2	Z6506	MAIN BEARING	2

### Centrifugal Unloader Group

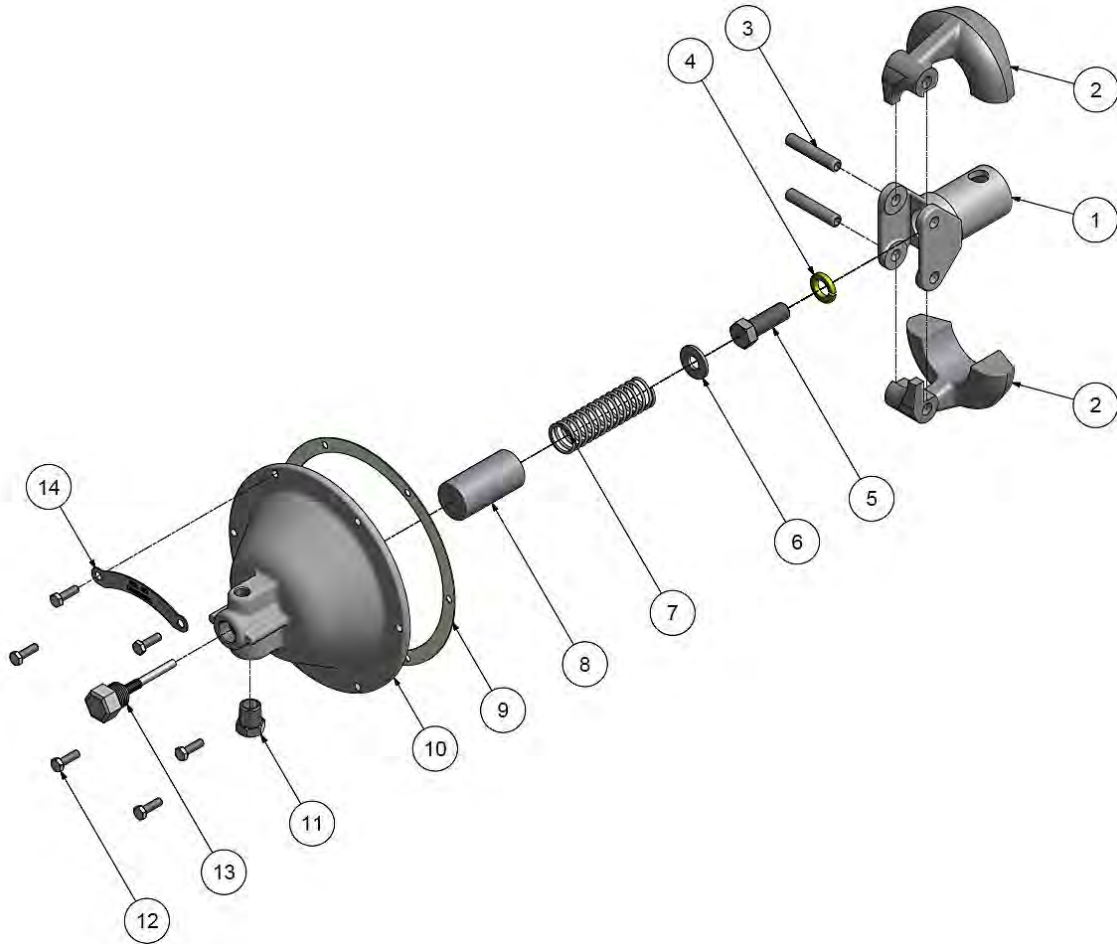

352CAP810-01  
Ref Drawing

## Centrifugal Unloader Group

**CENTRIFUGAL UNLOADER GROUP****300CAP890**

Item	Part Number	Description	Qty
1	SE583B	SPINDLE,GOVERNOR	1
2	SE582B	WEIGHT,GOVERNOR	2
3	SE592A	PIN, GOVERNOR WEIGHT	2
4	95B4Z	WASHER-LOCK	1
5	M2345	SCREW (torque @ 470 in-lbs)	1
6	M912A	SPACER,CENTRIFUGAL UNLOADER	1
7	SE590	SPRING,GOVERNOR	1
8	SE587	SLEEVE, SPRING	1
9	SE1489	GASKET,GOVERNOR COVER	1
10	TEN010354	GOVERNOR HOUSING COVER	1
11	TEN013303	BREATHER	1
12	M3473	SCREW (torque @ 60 in-lbs)	6
13	Z12414A	RELEASE VALVE KIT	1
14	M3658	SERIAL NUMBER PLATE	1

**REPAIR PARTS**

Item	Part Number	Description	Qty
-	Z764	COMPRESSOR GASKET SET (excludes valve gaskets)	1

# Piston/Rod Group – Low Pressure

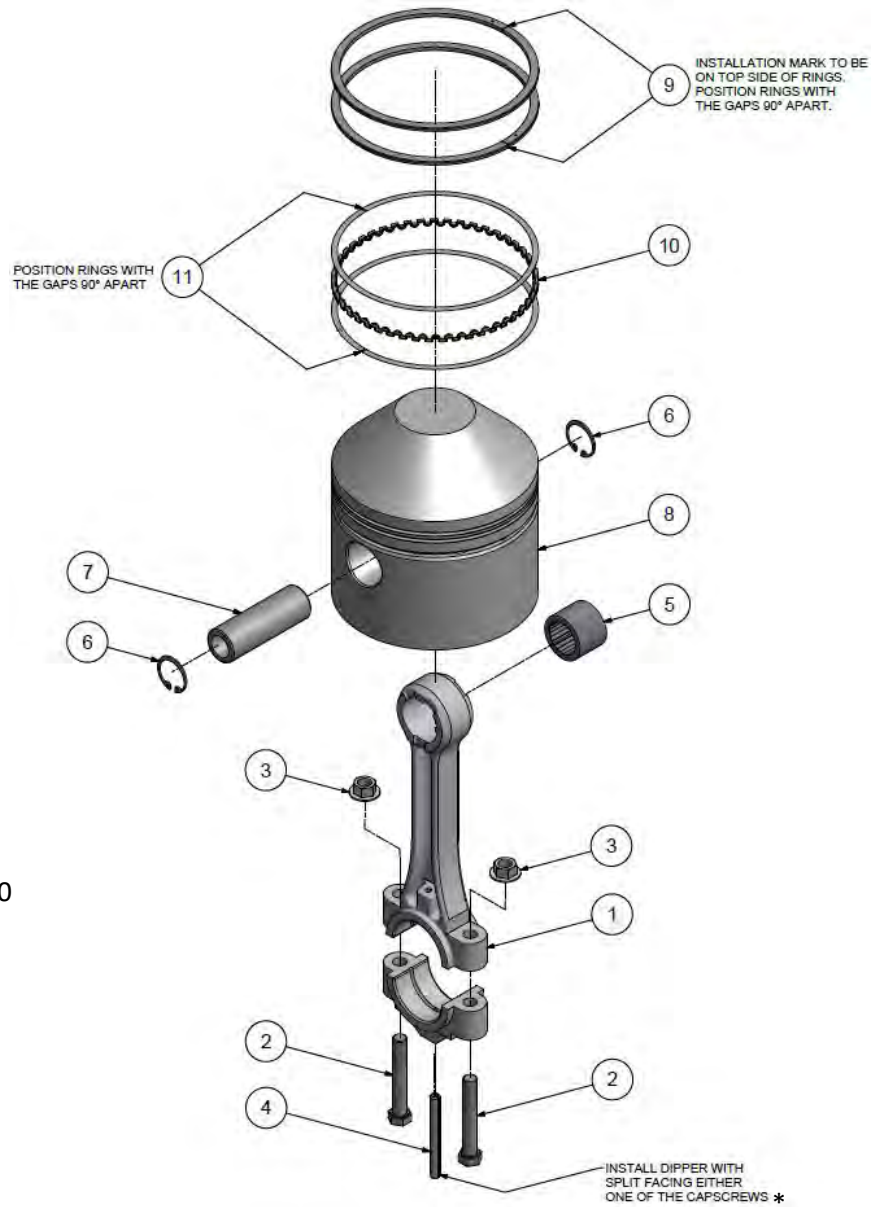

373CAP810-00  
Ref Drawing

\* ORIENT ROD ON CRANKSHAFT SO THAT THE SPLIT EDGE IS FACING THE DIRECTION OF TRAVEL THROUGH LUBRICANT

Piston/Rod Group – Low Pressure

**LOW PRESSURE ROD/PISTON GROUP**

**305CAP4056**

Item	Part Number	Description	Qty
1	M1384*	CONNECTING ROD	1
2	P03458A	SCREW (torque @ 400 in-lbs)	2
3	P03459A	NUT	2
4	P03440A	OIL DIPPER	1
5	P03430A	BEARING,WRIST PIN	1
6	P03434A	RING,RETAINING	2
7	M1395	PIN,PISTON	1
8	M1906	PISTON	1
9	P09498A*	RING,PISTON	2
10	P03946B1*	RING,EXPANDER	1
11	P03946B2*	RING,RAIL	2

\*not sold separately – see repair parts

**REPAIR PARTS**

Item	Part Number	Description	Qty
1-5	Z658	CONNECTING ROD ASSEMBLY KIT	1
6-8	ZM1906	PISTON KIT, LOW PRESSURE WITH PIN	1
9-11	Z9087	RING SET, LOW PRESSURE	1
6-11	Z9108	PISTON & RING KIT, LOW PRESSURE	1
-	Z9109	COMPLETE RING SET, HIGH & LOW PRESSURE	1



Piston/Rod Group – High Pressure

**HIGH PRESSURE ROD/PISTON GROUP**

**304CAP4056**

Item	Part Number	Description	Qty
1	M1384*	CONNECTING ROD	1
2	P03458A	SCREW (torque @ 400 in-lbs)	2
3	P03459A	NUT	2
4	P03440A	OIL DIPPER	1
5	P03430A	BEARING,WRIST PIN	1
6	P03434A	RING,RETAINING	2
7	M1383	PIN,PISTON	1
8	M1393	PISTON	1
9	P03427A*	RING,PISTON	2
10	P03428B1*	RING,EXPANDER	1
11	P03428B2*	RING,RAIL	2

\*not sold separately – see repair parts

**REPAIR PARTS**

Item	Part Number	Description	Qty
1-5	Z658	CONNECTING ROD ASSEMBLY KIT	1
6-8	ZM1393	PISTON KIT, HIGH PRESSURE WITH PIN	1
9-11	Z9088	RING SET, HIGH PRESSURE	1
6-11	Z9107	PISTON & RING KIT, HIGH PRESSURE	1
-	Z9109	COMPLETE RING SET, HIGH & LOW PRESSURE	1

### Cylinder Group – Standard

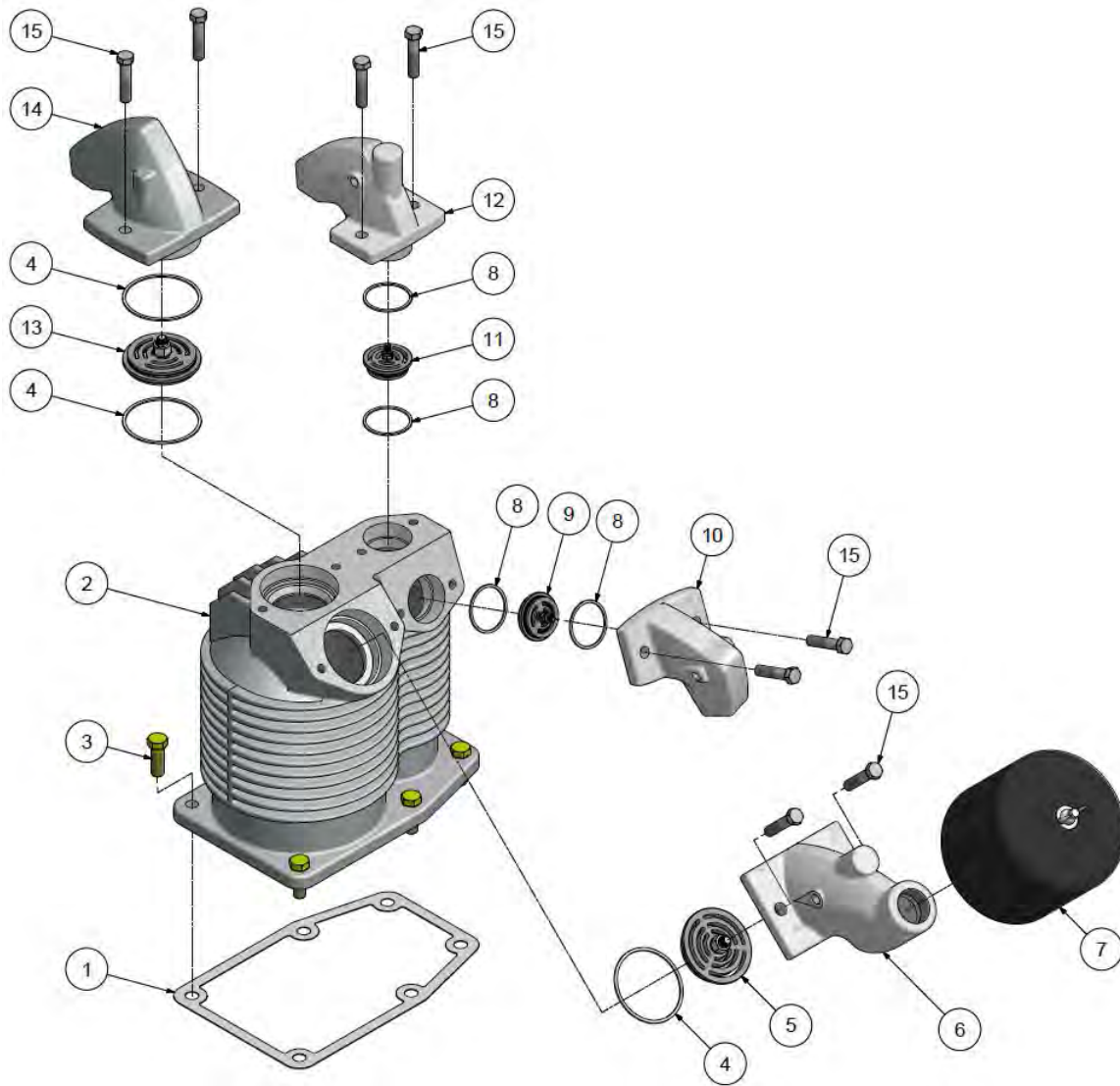

374CAP810-00  
Ref Drawing

## Cylinder Group – Standard

## CYLINDER GROUP

301CAP4042

Item	Part Number	Description	Qty
1	M1391	GASKET, CYLINDER FLANGE	1
2	P05863D	CYLINDER	1
3	M3461	SCREW (torque @ 900 in-lbs)	6
4	P07352A	GASKET, VALVE, LP, ALUMINUM	3
5	P03436A	VALVE, LP, INTAKE	1
6	P09711D	MANIFOLD, LP INTAKE	1
7	P07447A	FILTER SILENCER	1
8	P07353A	GASKET, VALVE, HP, ALUMINUM	4
9	P04815A	VALVE, HP, EXHAUST	1
10	M1508	MANIFOLD, HP EXHAUST	1
11	M2878	VALVE, HP, INTAKE	1
12	M1431	MANIFOLD, HP INTAKE	1
13	P03437A	VALVE, LP, EXHAUST	1
14	M1423	MANIFOLD, LP EXHAUST	1
15	P04779A	SCREW (torque @ 230 in-lbs)	8

## REPAIR PARTS

Item	Part Number	Description	Qty
4, 5, 8, 9, 11, 13	Z656	COMPLETE VALVE SET, WITH GASKET SET	1
4, 8	Z657	COMPLETE VALVE GASKET SET	1
-	Z10888	COMPRESSOR GASKET SET (excludes valve gaskets)	1

### Cylinder Group – with Head Unloaders (optional)

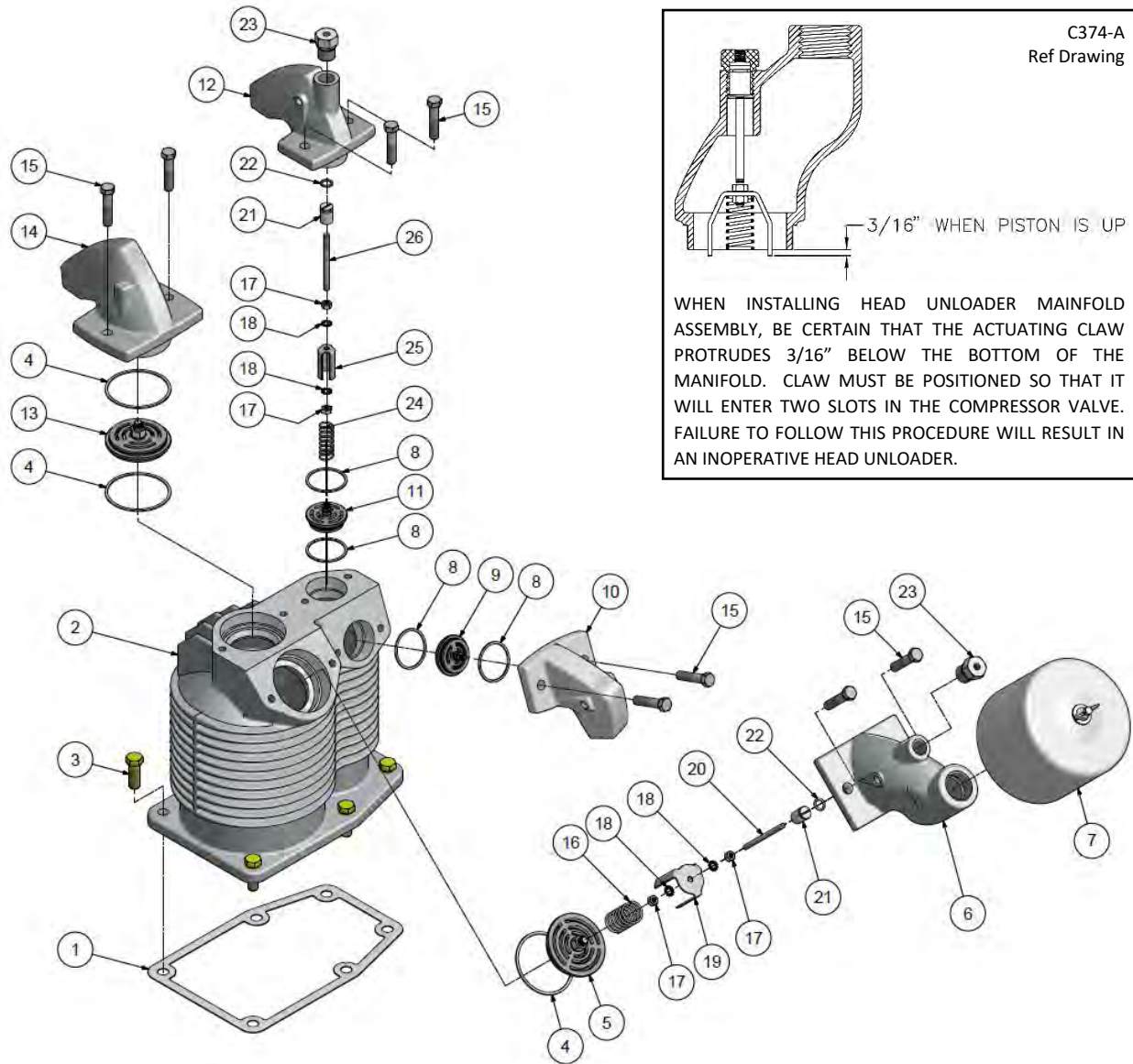

375CAP810-00  
Ref Drawing

## Cylinder Group – with Head Unloaders (optional)

### CYLINDER GROUP - HEAD UNLOADERS

303CAP4042

Item	Part Number	Description	Qty
1	M1391	GASKET, CYLINDER FLANGE	1
2	P05863D	CYLINDER	1
3	M3461	SCREW (torque @ 900 in-lbs)	6
4	P07352A	GASKET, VALVE, LP, ALUMINUM	3
5	P03436A	VALVE, LP, INTAKE	1
6	P09712D	MANIFOLD, LP INTAKE, HU	1
7	P07447A	FILTER SILENCER	1
8	P07353A	GASKET, VALVE, HP, ALUMINUM	4
9	P04815A	VALVE, HP, EXHAUST	1
10	M1508	MANIFOLD, HP EXHAUST	1
11	M2878	VALVE, HP, INTAKE	1
12	M1426	MANIFOLD, HP INTAKE, HU	1
13	P03437A	VALVE, LP, EXHAUST	1
14	M1423	MANIFOLD, LP EXHAUST	1
15	P04779A	SCREW (torque @ 230 in-lbs)	8
16	M1449	SPRING, LP	1
17	M926A	NUT	4
18	M919A	LOCK WASHER	4
19	M1815	UNLOADER FORK, LP	1
20	M1448	UNLOADER PISTON ROD, LP	1
21	P02287A	UNLOADER PISTON	2
22	P02547A	O-RING	2
23	P02306B	UNLOADER VALVE CYLINDER	2
24	M1450	SPRING, HP	1
25	M1447	UNLOADER FORK, HP	1
26	M1452	UNLOADER PISTON ROD, HP	1

### REPAIR PARTS

Item	Part Number	Description	Qty
4, 5, 8, 9, 11, 13	Z656	COMPLETE VALVE SET, WITH GASKET SET	1
4, 8	Z657	COMPLETE VALVE GASKET SET	1
-	Z10888	COMPRESSOR GASKET SET (excludes valve gaskets)	1
-	HUK503	KIT, HEAD UNLOADER CONVERSION (includes manifolds, unloader valves assemblies, pilot valve, fittings and tubing)	1

### Tubing and Control Group – Standard

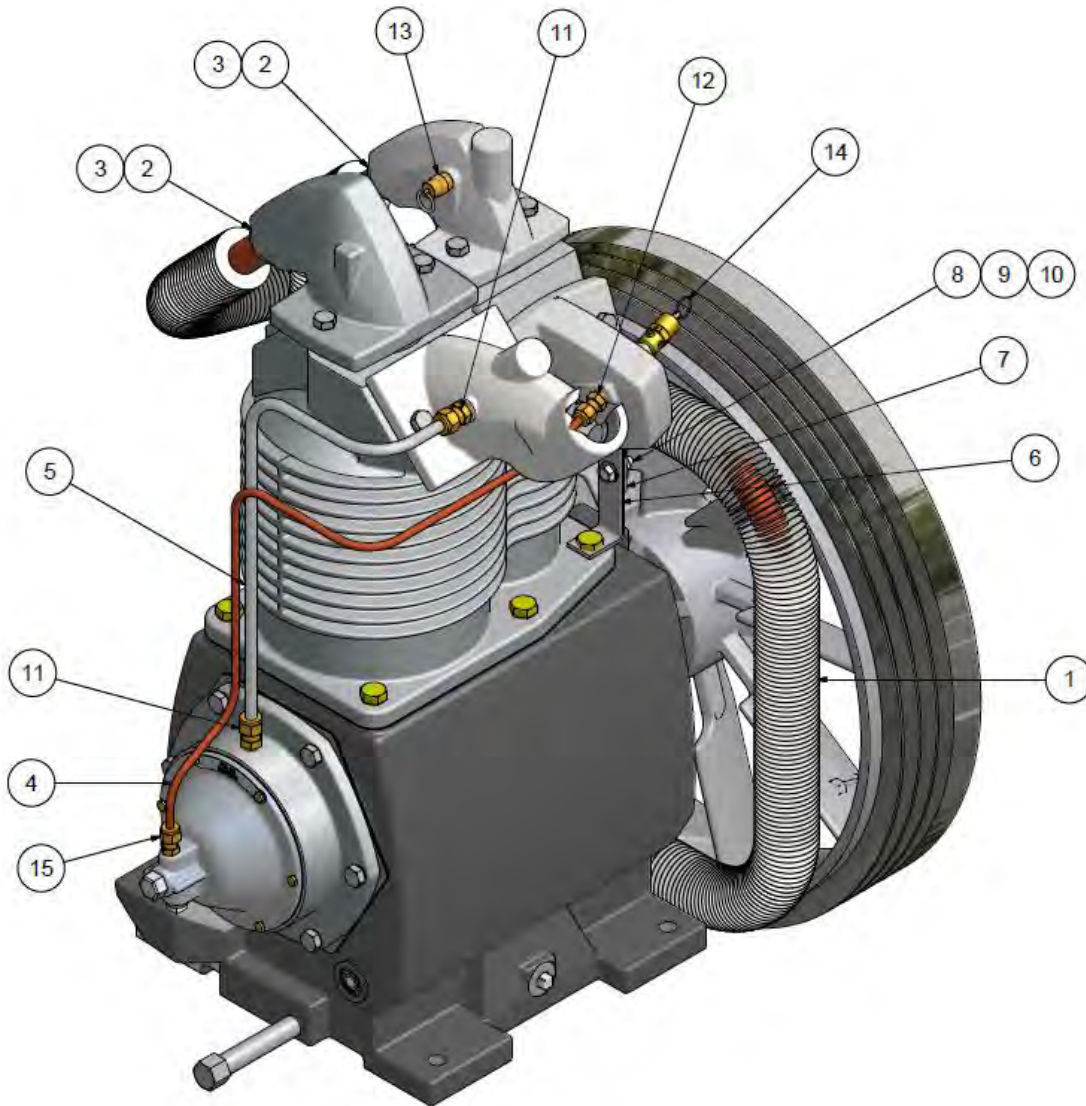

376CAP810-00  
Ref Drawing

**Tubing and Control Group – Standard**

<b>TUBING &amp; CONTROL GROUP</b>			<b>304CAP272</b>
<b>Item</b>	<b>Part Number</b>	<b>Description</b>	<b>Qty</b>
1	CQP14757D	INTERCOOLER	1
2	M1418	COMPRESSION NUT	2
3	P06064A	COMPRESSION FERRULE	2
4	304CAP294	RELEASE VALVE TUBE	1
5	M1622	BREATHER TUBE	1
6	P13808A	BRACKET	1
7	P12594A	CLAMP	1
8	M1454	SCREW	1
9	M3056	WASHER	1
10	M3485	NUT	1
11	M2864	COMPRESSION FITTING, STRAIGHT	2
12	M2862	COMPRESSION FITTING, STRAIGHT	1
13	M3685	PRESSURE RELIEF VALVE, 75 PSIG	1
14	P09704A	PRESSURE RELIEF VALVE, 270 PSIG	1
15	M2863	COMPRESSION FITTING, STRAIGHT	1

### Tubing and Control Group – with Head Unloaders (optional)

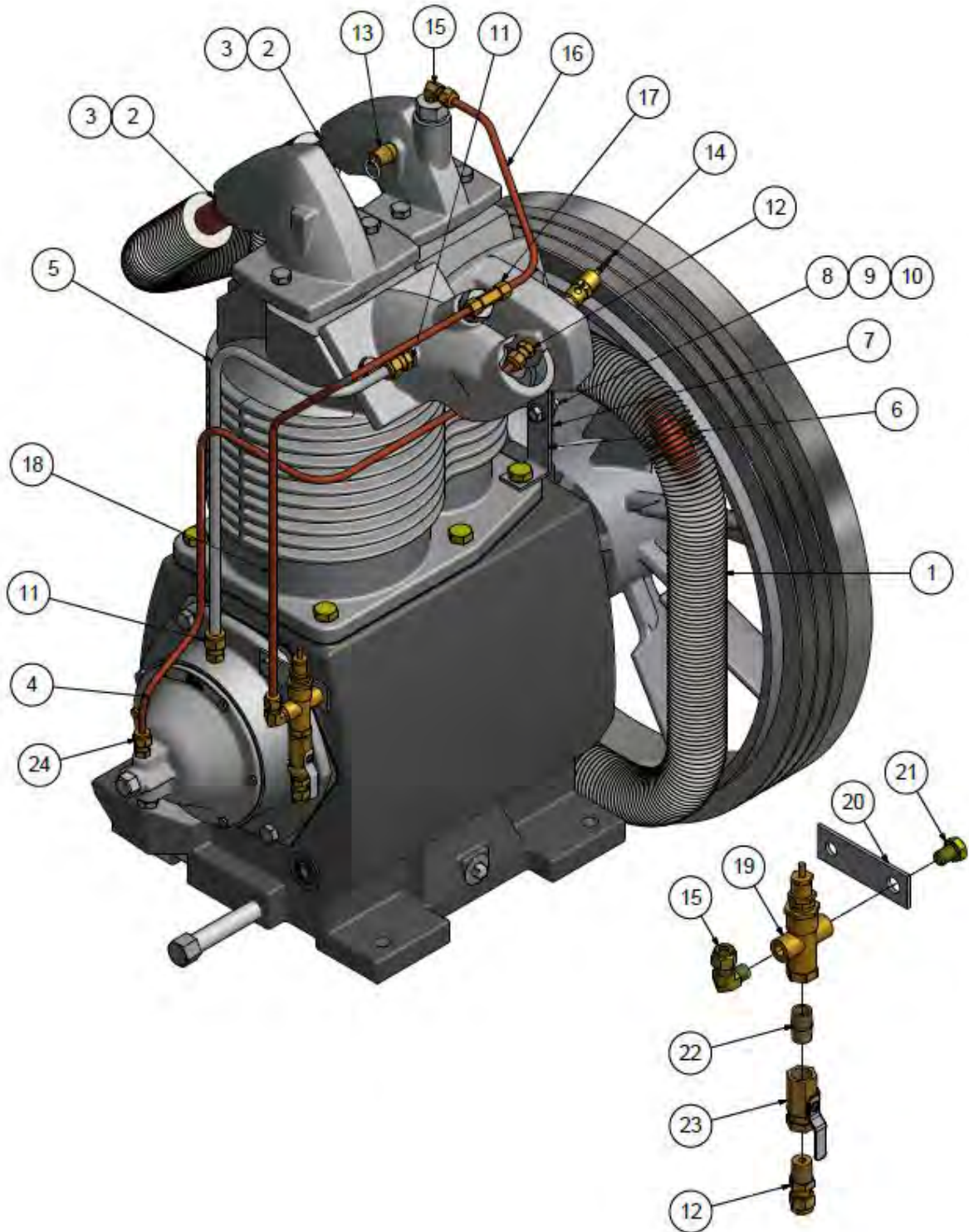

377CAP810-01  
Ref Drawing

**Tubing and Control Group – with Head Unloaders (optional)**

**TUBING & CONTROL GROUP - HEAD UNLOADERS**

**305CAP272**

Item	Part Number	Description	Qty
1	CQP14757D	INTERCOOLER	1
2	M1418	COMPRESSION NUT	2
3	P06064A	COMPRESSION FERRULE	2
4	304CAP294	RELEASE VALVE TUBE	1
5	M1622	BREATHER TUBE	1
6	P13808A	BRACKET	1
7	P12594A	CLAMP	1
8	M1454	SCREW	1
9	M3056	WASHER	1
10	M3485	NUT	1
11	M2864	COMPRESSION FITTING, STRAIGHT	2
12	M2862	COMPRESSION FITTING, STRAIGHT	2
13	M3685	PRESSURE RELIEF VALVE, 75 PSIG	1
14	P09704A	PRESSURE RELIEF VALVE, 270 PSIG	1
15	M2868	COMPRESSION FITTING, ELBOW	2
16	308CAP294	MANIFOLD TUBE	1
17	M2879	COMPRESSION FITTING, TEE	1
18	307CAP294	UNLOADER TUBE	1
19	M2854	PILOT VALVE 90-120# (125 psi discharge)	1
19	M2853	PILOT VALVE 140-170# (175 psi discharge)	1
20	M807	BRACKET,PILOT VALVE MOUNTING	1
21	M3465	SCREW	1
22	63Z15	PIPE NIPPLE	1
23	VP1022988	BALL VALVE	1
24	M2863	COMPRESSION FITTING, STRAIGHT	1

**REPAIR PARTS**

Item	Part Number	Description	Qty
-	HUK503	KIT, HEAD UNLOADER CONVERSION (includes manifolds, unloader valves assemblies, pilot valve, fittings and tubing)	1

### High Temperature Switch (optional)



TEN008394-01  
Ref Drawing

#### HIGH TEMPERATURE SWITCH

TEN008394

Item	Part Number	Description	Qty
1	TEN001792	SWITCH, HIGH TEMP, 450F	1
2	003FE98	CORD GRIP	1
3	TEN008088	SEALING RING	1
4	TEN008089	LOCK NUT	1
5	M1003B	PIPE TEE	1
6	P08798A	PIPE NIPPLE	1

### Filter Maintenance Indicator (optional)

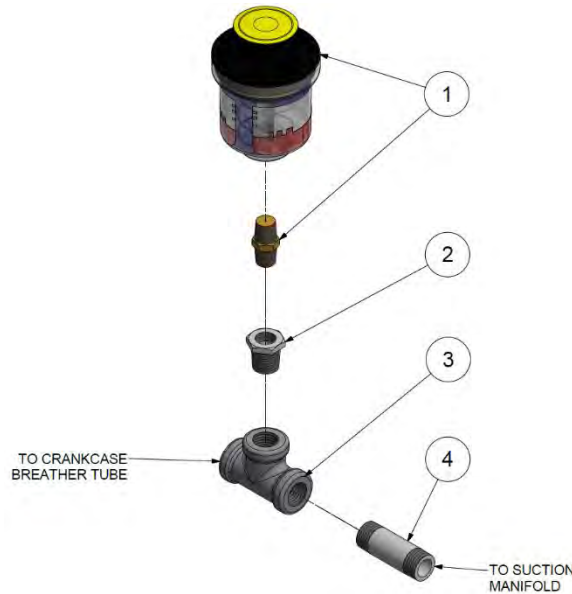

#### FILTER MAINTENANCE INDICATOR

TEN013353

Item	Part Number	Description	Qty
1	P11683A	FILTER INDICATOR	1
2	64E44	PIPE BUSHING	1
3	M1003B	PIPE TEE	1
4	M1016B	PIPE NIPPLE	1

### Low Oil Shutdown Control (optional)

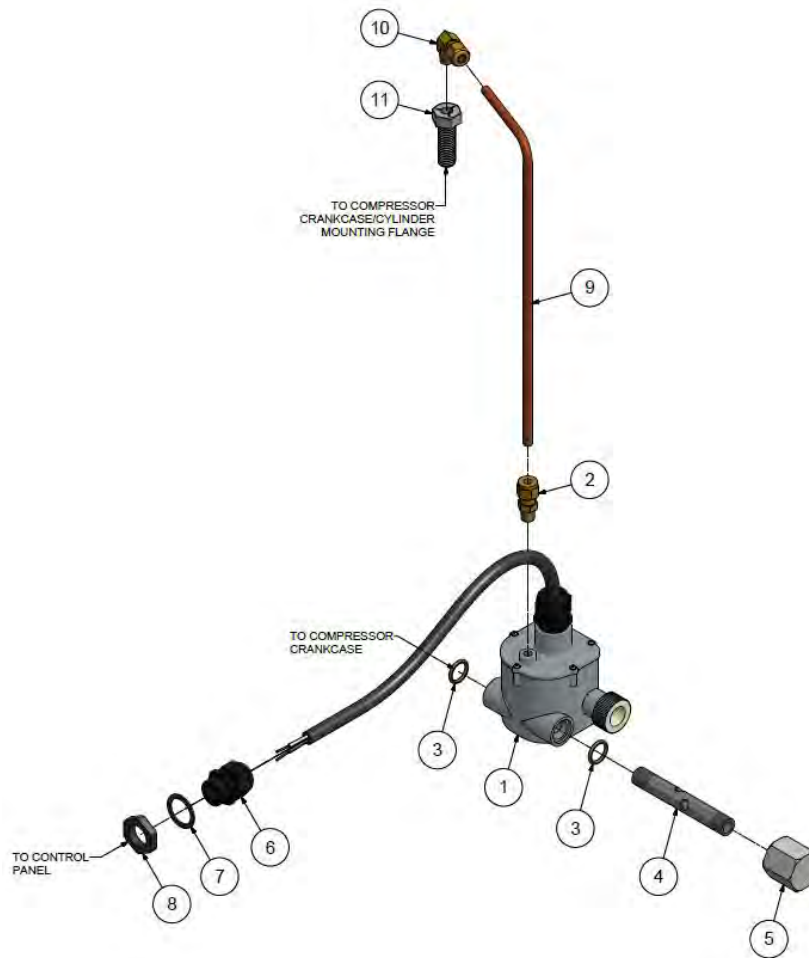

TEN008802-00  
Ref Drawing

#### LOW OIL SHUTDOWN CONTROL

TEN008802

Item	Part Number	Description	Qty
1	TEN008741	SWITCH-LOW OIL SHUTDOWN CONTROL	1
2	M2863	COMPRESSION FITTING, STRAIGHT	1
3	2009222	O-RING	2
4	CC1153304	OIL TUBE	1
5	LO30	RETAINER CAP	1
6	003FE98	CORD GRIP	1
7	TEN008088	SEALING RING	1
8	TEN008089	LOCK NUT	1
9	CC1007631	VENT TUBE	1
10	M2868	COMPRESSION FITTING, STRAIGHT	1
11	M1500	VENT FITTING	1

#### REPAIR PARTS

Item	Part Number	Description	Qty
1-11	TEN008809	KIT-LOSC w/CABLE, COMPLETE	1
1-4	TEN008855	KIT-LOSC w/CABLE, REPLACEMENT	1

## Section 3 – Electric Packages

### Horizontal Package – Simplex

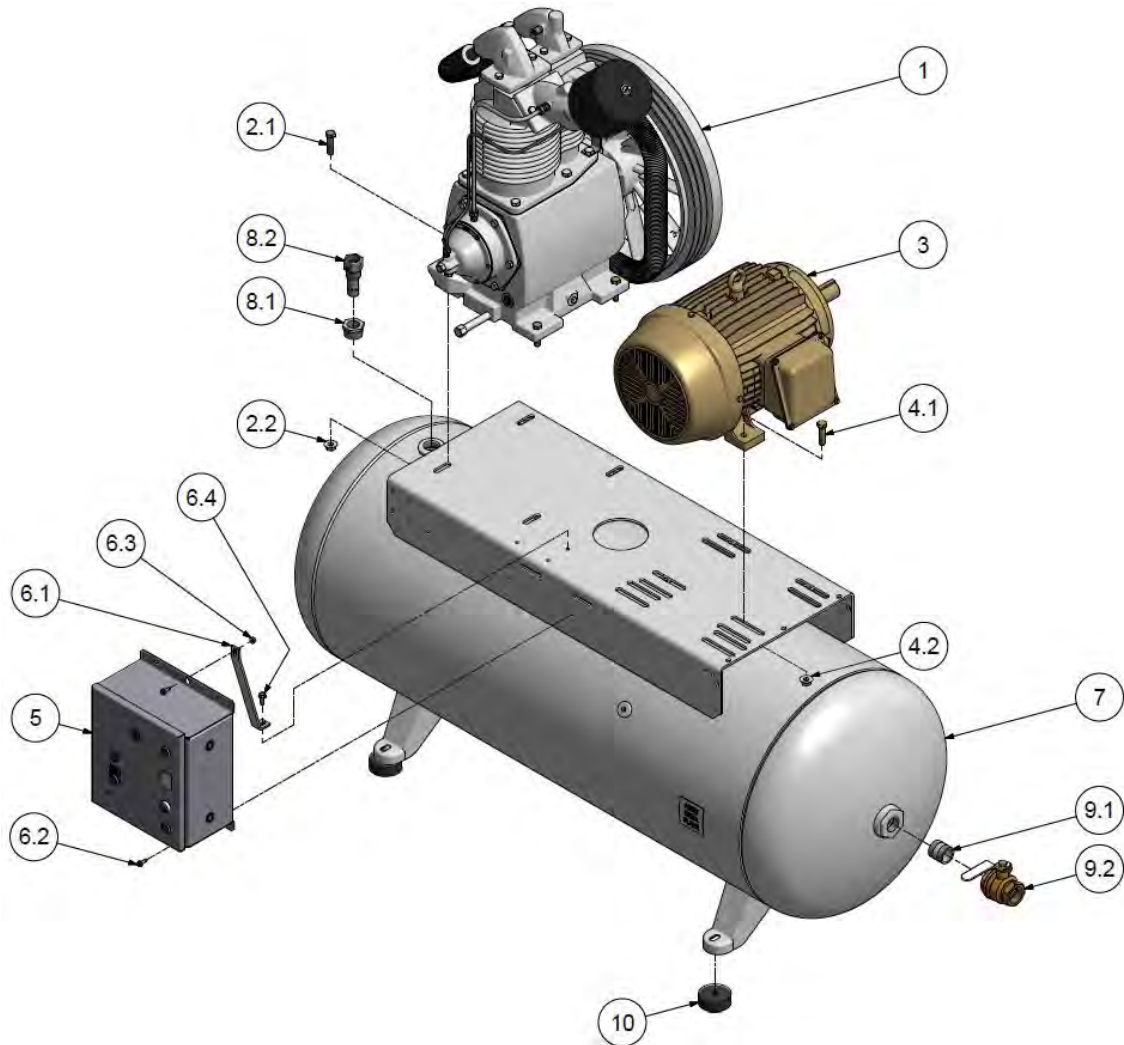

437CAS810-00  
Ref Drawing

## Horizontal Package – Simplex

Item	Part Number	Description	Qty
<b>COMPRESSOR</b>			<b>R2-30A</b>
1	R2-30A-P08	R40 COMPRESSOR	1
1	R2-30A-P22	R40 COMPRESSOR W/HEAD UNLOADERS	1
<b>COMPRESSOR MOUNTING</b>			<b>403CAS4017</b>
2.1	M3470	SCREW	4
2.2	M3486	NUT	4
<b>MOTOR</b>			
3	-	SEE MOTOR PART NUMBER LISTING ON FOLLOWING PAGE	1
<b>MOTOR MOUNTING</b>			<b>403CAS4015</b>
4.1	M3470	SCREW	4
4.2	M3486	NUT	4
<b>SIMPLEX CONTROL PANEL</b>			
5	-	SEE PART NUMBER LISTING IN CONTROL PANEL MANUAL	1
<b>PANEL MOUNTING (HORIZONTAL)</b>			
6.1	TEN008120	BRACKET-PANEL, 120 & 240GL HORIZONTAL	1
6.2	M3349	SCREW	3
6.3	50AW3	NUT	1
6.4	M1454	SCREW	1
<b>HORIZONTAL AIR RECEIVER / BASE MOUNT</b>			
7	TEN005640	RECEIVER, 120 GALLON HORIZONTAL, 200PSI	1
7	TEN007574	RECEIVER, 240 GALLON HORIZONTAL, 200PSI	1
7	P03538C	BASE MOUNT PLATE (NOT SHOWN)	1
<b>CHECK VALVE</b>			<b>401CAS4019</b>
8.1	M954B	BUSHING	1
8.2	P03690A	VALVE,CHECK,INTANK,1"	1
<b>BALL VALVE</b>			<b>406CAS4061</b>
9.1	M1039B	PIPE NIPPLE	1
9.2	M2688	BALL VALVE	1
<b>VIBRATION ISOLATORS (OPTIONAL)</b>			
10	P14608A	ISOLATOR,VIBRATION,4"DIA.	4

# Horizontal Package – Duplex

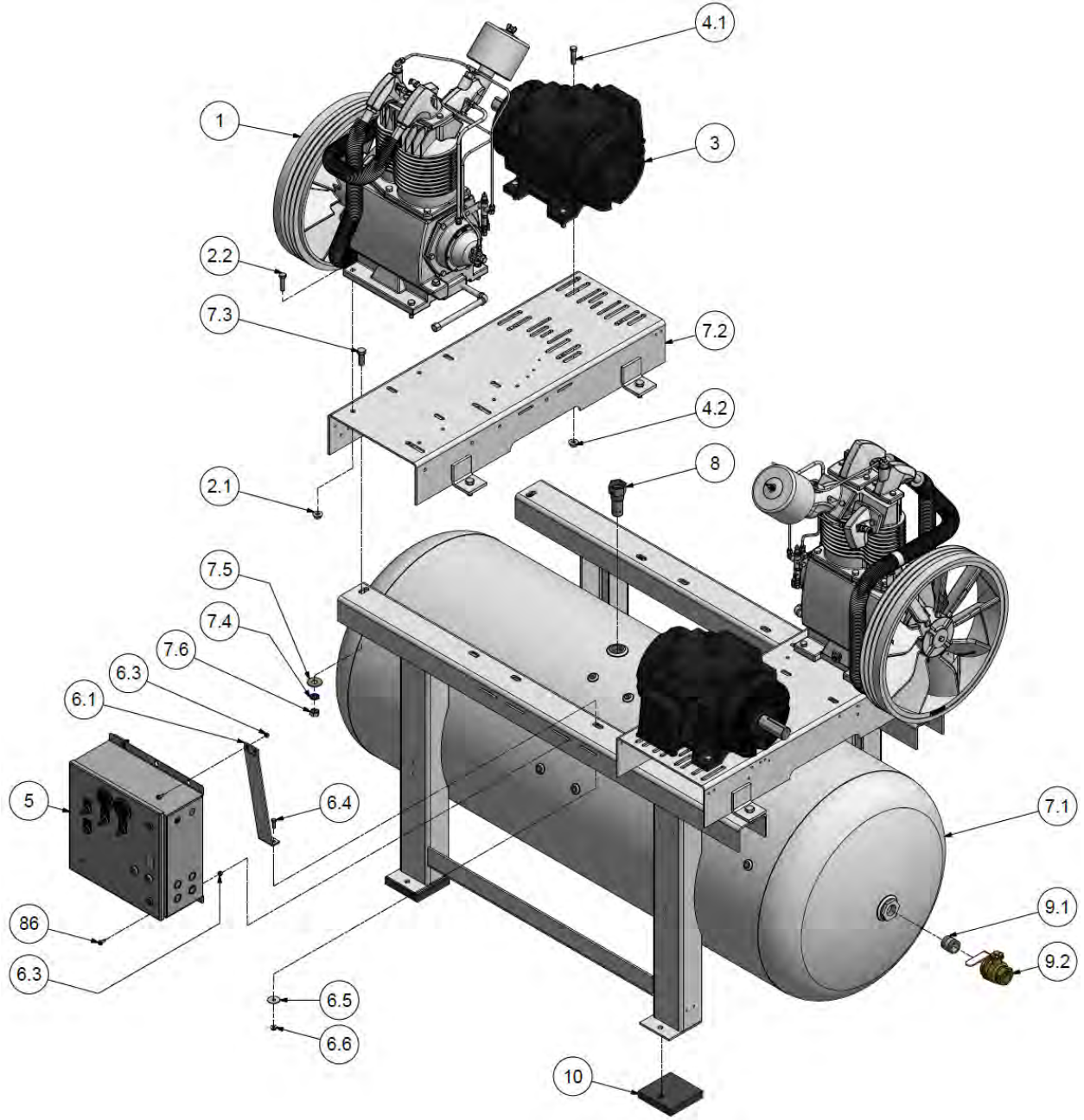

424CAD810-00  
Ref Drawing

## Horizontal Package – Duplex

Item	Part Number	Description	Qty
<b>COMPRESSOR</b>			<b>R2-30A</b>
1	R2-30A-P08	R40 COMPRESSOR	2
1	R2-30A-P22	R40 COMPRESSOR W/HEAD UNLOADERS	2
<b>COMPRESSOR MOUNTING</b>			<b>403CAS4017</b>
2.1	M3470	SCREW	8
2.2	M3486	NUT	8
<b>MOTOR</b>			
3	-	SEE MOTOR PART NUMBER LISTING ON FOLLOWING PAGE	2
<b>MOTOR MOUNTING</b>			<b>403CAS4015</b>
4.1	M3470	SCREW	4
4.2	M3486	NUT	4
<b>DUPLEX CONTROL PANEL</b>			
5	-	SEE PART NUMBER LISTING IN CONTROL PANEL MANUAL	1
<b>PANEL MOUNTING</b>			
6.1	TEN018265	BRACKET-PANEL	2
6.2	M1998	SCREW	4
6.3	50AW3	NUT	4
6.4	M1454	SCREW	2
6.5	95A32Z	WASHER	2
6.6	M3485	NUT	2
<b>HORIZONTAL AIR RECEIVER</b>			
7.1	P12127D	RECEIVER, 240 GALLON HORIZONTAL, 200PSI	1
7.2	P03538C	BASE PLATE	2
7.3	655EF070	SCREW	8
7.4	M1663	LOCK WASHER	8
7.5	M1276	FLAT WASHER	8
7.6	M1662	NUT	8
<b>CHECK VALVE</b>			
8.2	P03590A	CHECK VALVE	1
<b>BALL VALVE</b>			<b>406CAS4061</b>
9.1	M1039B	PIPE NIPPLE	1
9.2	M2688	BALL VALVE	1
<b>VIBRATION ISOLATORS (OPTIONAL)</b>			
10	300CAD365	ISOLATOR,VIBRATION,5.5" SQUARE	4

## Electric Motor List

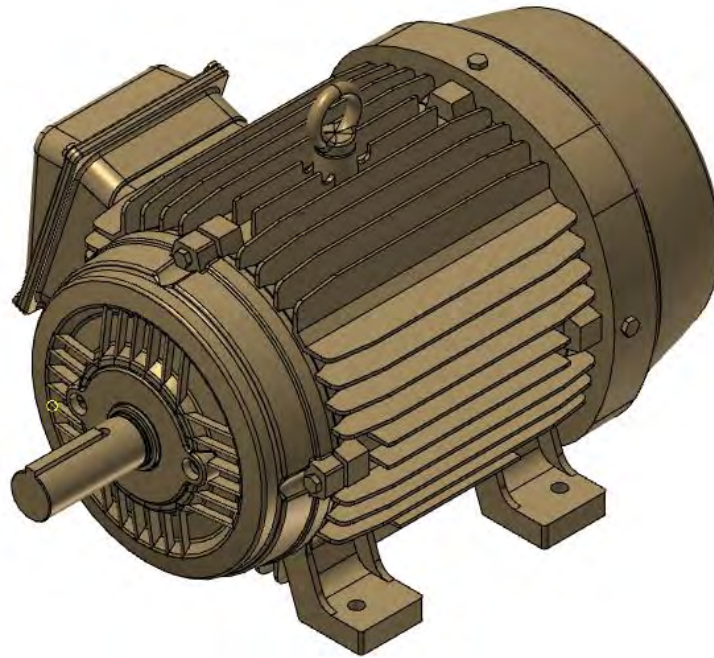

**MOTOR**

**R2-30A**

Item	Part Number	Description	Qty
3	24CA6668	MOTOR 15HP 208V 60HZ 3PH ODP	1
3	24CA6670	MOTOR 15HP 208V 60HZ 3PH TEFC	1
3	24CA6671	MOTOR 15HP 230V-460V 60HZ 3PH ODP	1
3	24CA6672	MOTOR 15HP 230V-460V 60HZ 3PH TEFC	1
3	24CA6673	MOTOR 15HP 575V 60HZ 3PH ODP	1
3	24CA6674	MOTOR 15HP 575V 60HZ 3PH TEFC	1

# Tank Drain – Manual

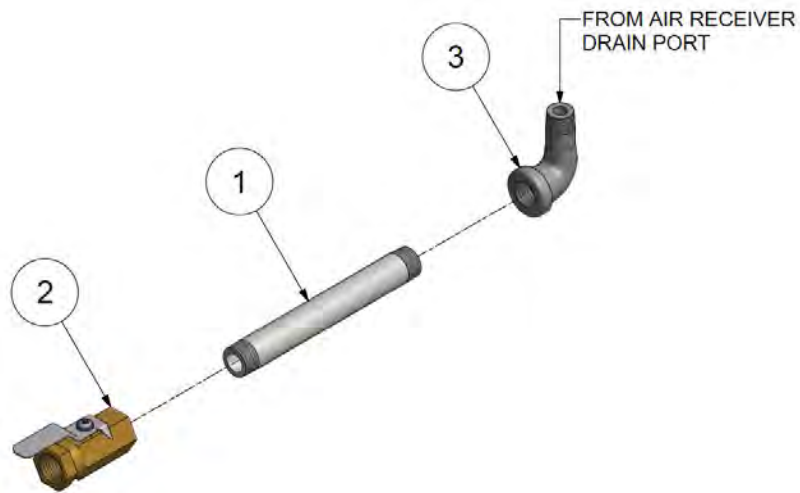

401CAS810-01  
Ref Drawing

## MANUAL TANK DRAIN (120 HORIZONTAL)

401CAS4027

Item	Part Number	Description	Qty
1	M1020B	PIPE NIPPLE, 8"	1
2	VP1022988	BALL VALVE	1
3	M980B	PIPE ELBOW	1
4	M1318 (NOT SHOWN)	PIPE BUSHING	1

**Tank Drain – Electric (optional)**

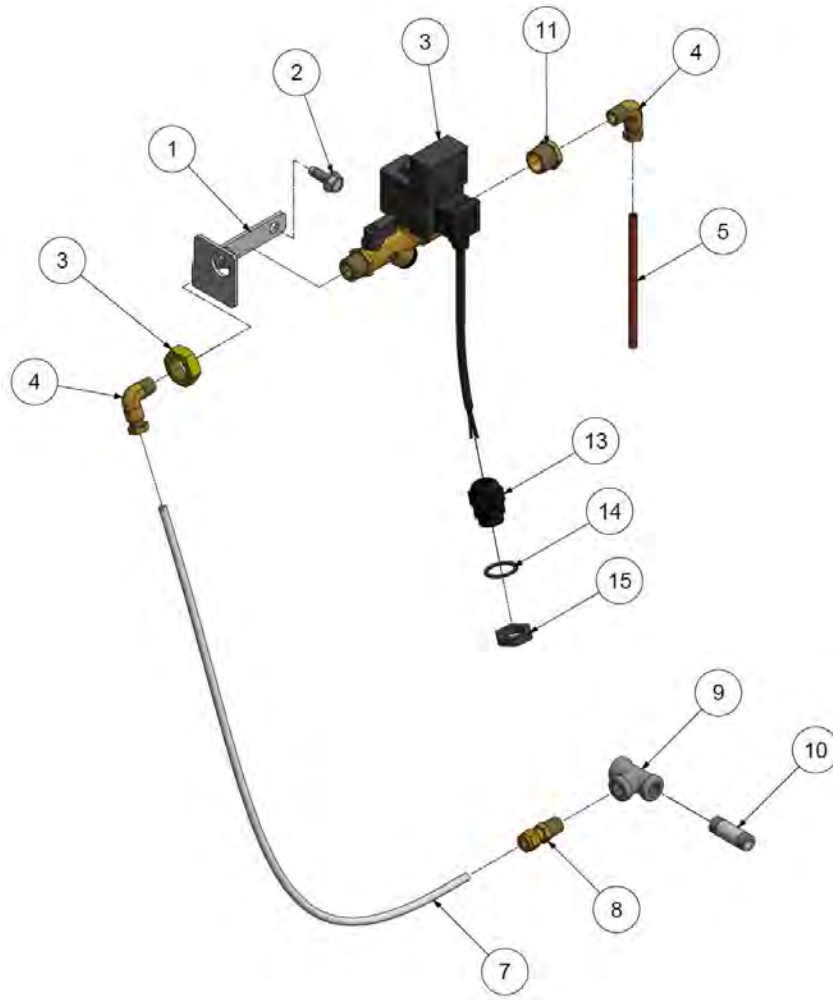

TEN002668-03  
Ref Drawing

**ELECTRIC TANK DRAIN**

**TEN002668**

Item	Part Number	Description	Qty
1	CC1049403	BRACKET	1
2	M1454	SCREW	2
3	TEN001368	VALVE,ETD,W/STRAINER	1
4	86A40	COMPRESSION FITTING, ELBOW	2
5	M2471	COPPER TUBING	6 in
7	P08084A	PLASTIC TUBING	5 ft
8	M2862	COMPRESSION FITTING, STRAIGHT	1
9	M1003B	PIPE TEE	1
10	M1016B	PIPE NIPPLE	1
11	M3080	PIPE BUSHING	1
13	003FE98	CORD GRIP	1
14	TEN008088	SEALING RING	1
15	TEN008089	LOCK NUT	1

### Control Group – Simplex Start/Stop

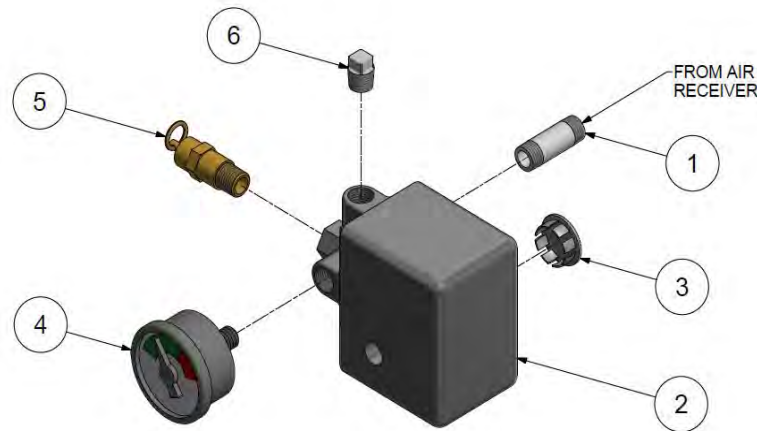

402CAS810-01  
Ref Drawing  
(Nema 1)

#### START/STOP CONTROL, NEMA 1

401CAS4052  
403CAS4052

Item	Part Number	Description	Qty
1	M1016B	PIPE NIPPLE, 1.5"	1
2	P14205A	SWITCH,PRESSURE,95-125 (125 psi discharge)	1
2	P14202A	SWITCH,PRESSURE,140-175 (175 psi discharge)	1
3	M2352	KNOCKOUT HOLE PLUG	1
4	M519C	PRESSURE GAUGE	1
5	M2843	PRESSURE RELIEF VALVE, 200#	1
6	64AA5	PIPE PLUG	1

#### START/STOP CONTROL, NEMA 4

405CAS4052

Item	Part Number	Description	Qty
1	M1016B	PIPE NIPPLE, 1.5"	1
2	P07333A	SWITCH,PRESSURE,N4 (125 or 175 psi discharge)	1
4	M519C	PRESSURE GAUGE	1
5	M2843	PRESSURE RELIEF VALVE, 200#	1
-	64K1 (not shown)	PIPE CROSS	1

### Control Group – Simplex Dual Control (optional)

408CAS810-02  
Ref Drawing  
(Nema 1)

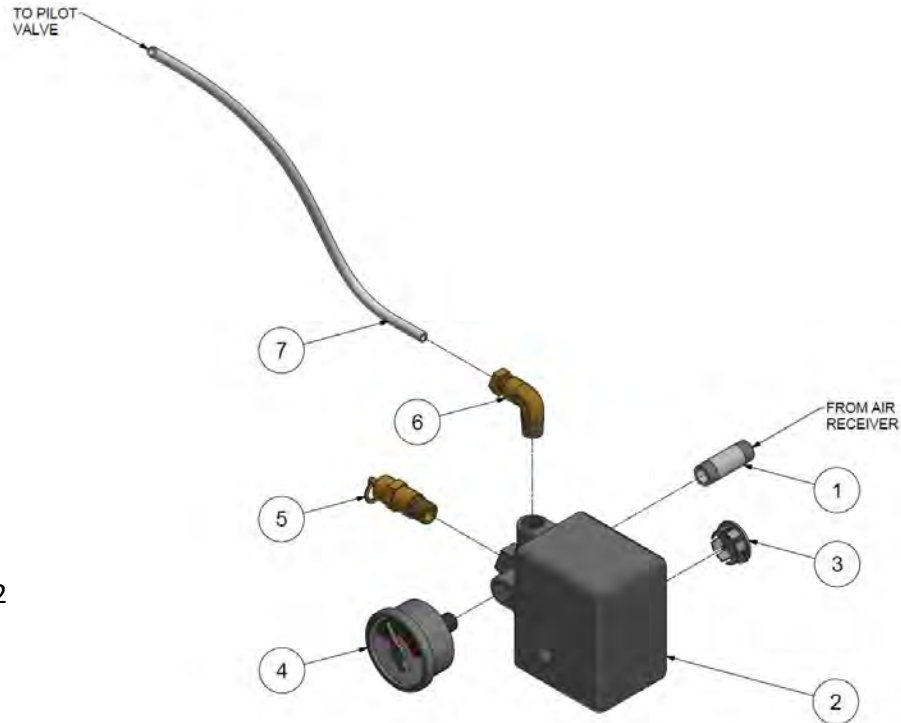

#### DUAL CONTROL, NEMA 1

407CAS4052  
411CAS4052

Item	Part Number	Description	Qty
1	M1016B	NIPPLE	1
2	P14205A	SWITCH,PRESSURE,95-125 (125 psi discharge)	1
2	P14202A	SWITCH,PRESSURE,140-175 (175 psi discharge)	1
3	M2352	KNOCKOUT HOLE PLUG	1
4	M519C	PRESSURE GAUGE	1
5	M2843	PRESSURE RELIEF VALVE, 200#	1
6	86A40	COMPRESSION FITTING, ELBOW	1
7	P08084A	PLASTIC TUBING	3.5 ft

#### DUAL CONTROL, NEMA 4

409CAS4052  
413CAS4052

Item	Part Number	Description	Qty
1	M1016B	NIPPLE	2
-	M1003B (not shown)	PIPE TEE	1
-	64K1 (not shown)	PIPE CROSS	1
2	P07333A	SWITCH,PRESSURE,N4 (125 or 175 psi discharge)	1
4	M519C	PRESSURE GAUGE	1
5	M2843	PRESSURE RELIEF VALVE, 200#	1
6	86A40	COMPRESSION FITTING, ELBOW	1
7	P08084A	PLASTIC TUBING	3 ft

### Control Group – Duplex Start/Stop

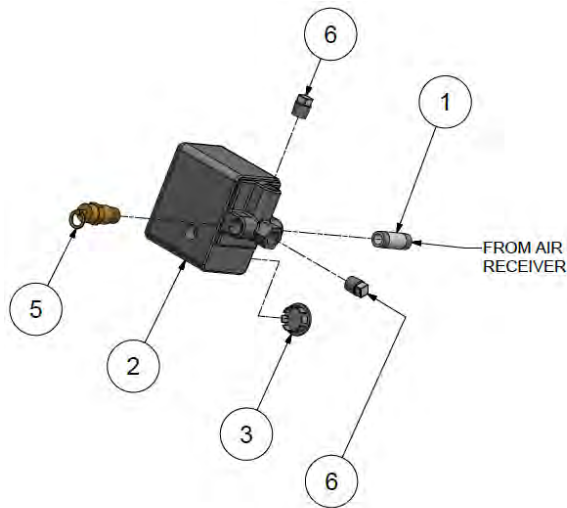

400CAD810-00  
Ref Drawing  
(Nema 1)

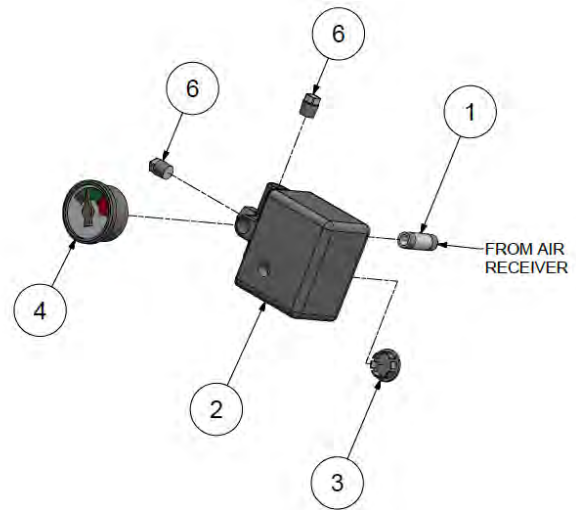

#### START/STOP CONTROL, NEMA 1

401CAD4052  
403CAD4052

Item	Part Number	Description	Qty
1	M1016B	PIPE NIPPLE, 1.5"	2
2	P14205A	SWITCH,PRESSURE,95-125 (125 psi discharge)	2
2	P14202A	SWITCH,PRESSURE,140-175 (175 psi discharge)	2
3	M2352	KNOCKOUT HOLE PLUG	2
4	M519C	PRESSURE GAUGE	1
5	M2843	PRESSURE RELIEF VALVE, 200#	1
6	64AA5	PIPE PLUG	4

#### START/STOP CONTROL, NEMA 4

405CAD4052

Item	Part Number	Description	Qty
1	M1016B	PIPE NIPPLE, 1.5"	2
2	P07333A	SWITCH,PRESSURE,N4 (125 or 175 psi discharge)	2
4	M519C	PRESSURE GAUGE	1
5	M2843	PRESSURE RELIEF VALVE, 200#	1
-	M1003B (not shown)	PIPE TEE	2

### Control Group – Duplex Dual Control (optional)

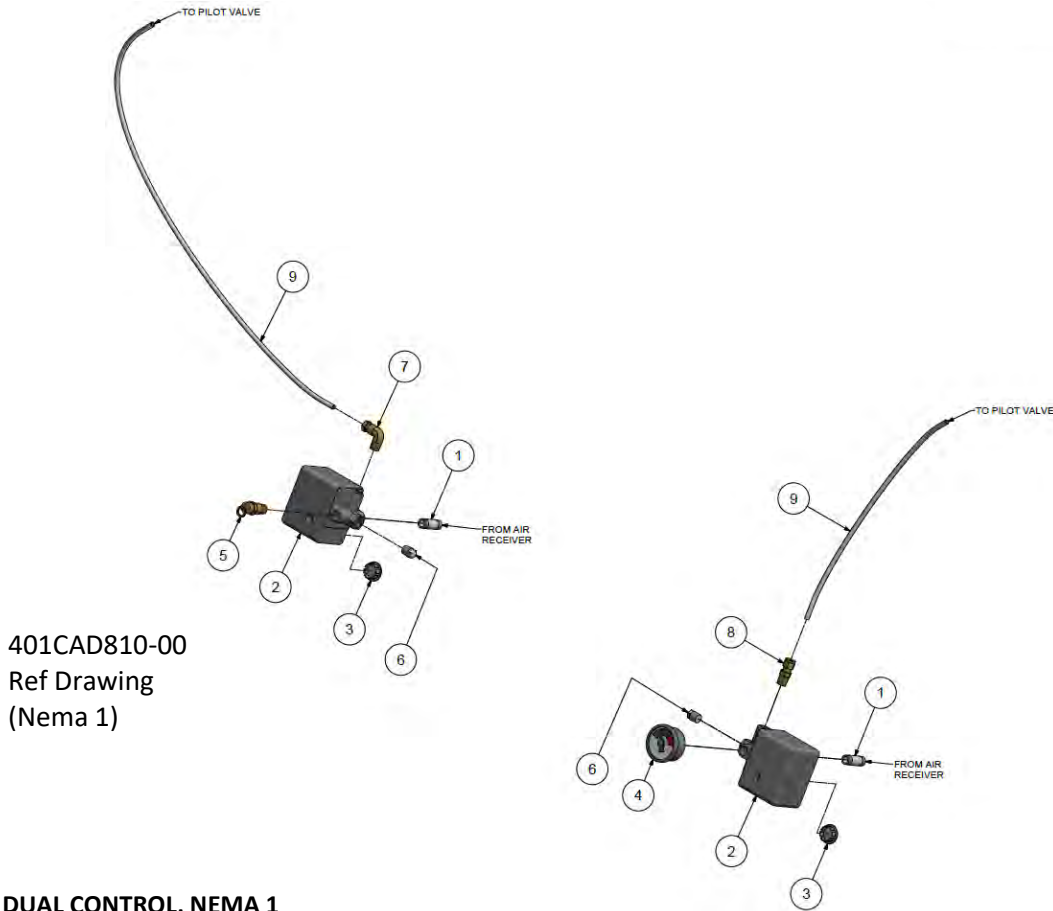

401CAD810-00  
Ref Drawing  
(Nema 1)

407CAD4052  
411CAD4052

**DUAL CONTROL, NEMA 1**

Item	Part Number	Description	Qty
1	M1016B	NIPPLE	2
2	P14205A	SWITCH,PRESSURE,95-125 (125 psi discharge)	2
2	P14202A	SWITCH,PRESSURE,140-175 (175 psi discharge)	2
3	M2352	KNOCKOUT HOLE PLUG 1/2	2
4	M519C	PRESSURE GAUGE	1
5	M2843	PRESSURE RELIEF VALVE, 200#	1
6	64AA5	PIPE PLUG	2
7	86A40	COMPRESSION FITTING, ELBOW	1
8	M2862	COMPRESSION FITTING, STRAIGHT	1
9	P08084A	TUBING,PLASTIC,1/4OD	4 ft

409CAD4052  
413CAD4052

**DUAL CONTROL, NEMA 4**

Item	Part Number	Description	Qty
1	M1016B	NIPPLE	2
-	M1003B (not shown)	PIPE TEE	2
-	64K1 (not shown)	PIPE CROSS	2
2	P07333A	SWITCH,PRESSURE,N4 (125 or 175 psi discharge)	2
4	M519C	PRESSURE GAUGE	1
5	M2843	PRESSURE RELIEF VALVE, 200#	1
7	86A40	COMPRESSION FITTING, ELBOW	1
8	M2862	COMPRESSION FITTING, STRAIGHT	1
9	P08084A	PLASTIC TUBING	4 ft

Power Transmission

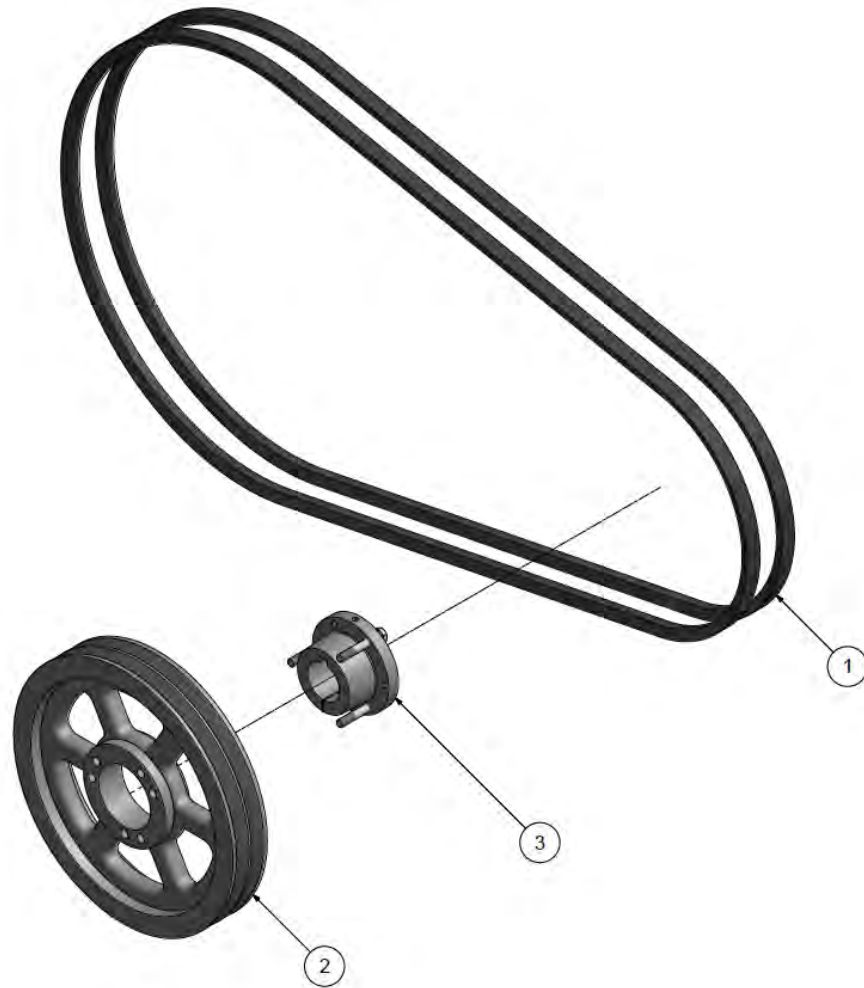

414CAS810-00  
Ref Drawing

**TRANSMISSION GROUP (R40,125PSI,15HP)**

**Z2946**

Item	Part Number	Description	Qty
1	B103	V BELT	3
2	P03710A	PULLEY,11.35OD,SK,3VA/B	1
3	P05622A	BUSHING,PULLEY,SK,1-5/8	1

**TRANSMISSION GROUP (R40,175PSI,15HP)**

**Z2947**

Item	Part Number	Description	Qty
1	B100	V BELT	3
2	P14238A	PULLEY,9.75OD,SK,3VA/B	1
3	P05622A	BUSHING,PULLEY,SK,1-5/8	1

**Belt Guard – Standard**

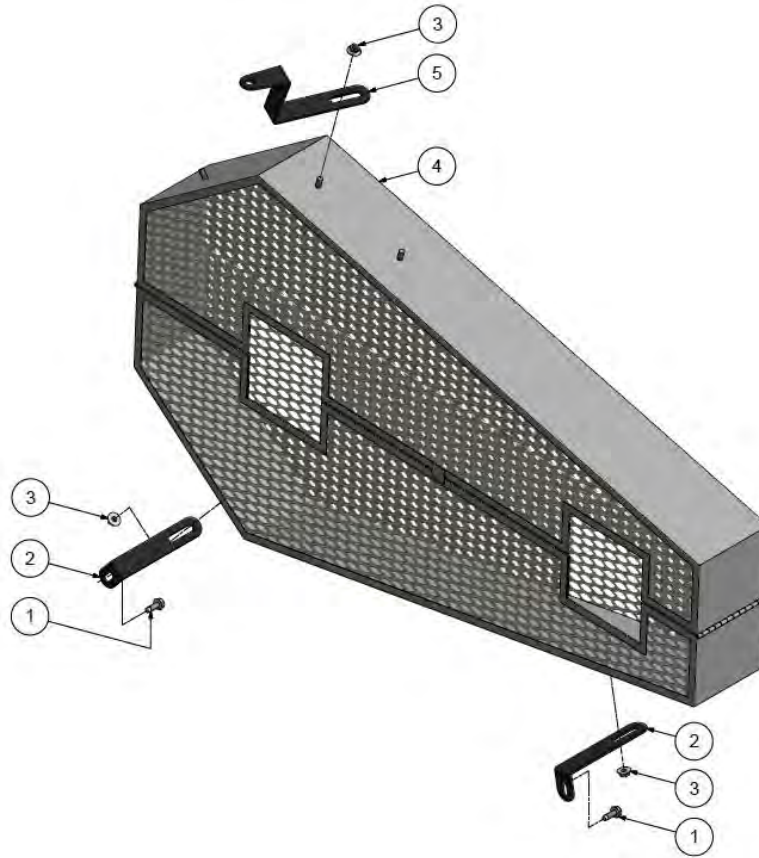

438CAS810-00  
Ref Drawing

**BELTGUARD - STANDARD**

**Z3727**

Item	Part Number	Description	Qty
1	M1454	SCREW	2
2	M1535	BRACKET	2
3	M3485	NUT	3
4	P05620D	BELTGUARD	1
5	P05730A	BRACKET	1

### Belt Guard – with Aftercooler (optional)

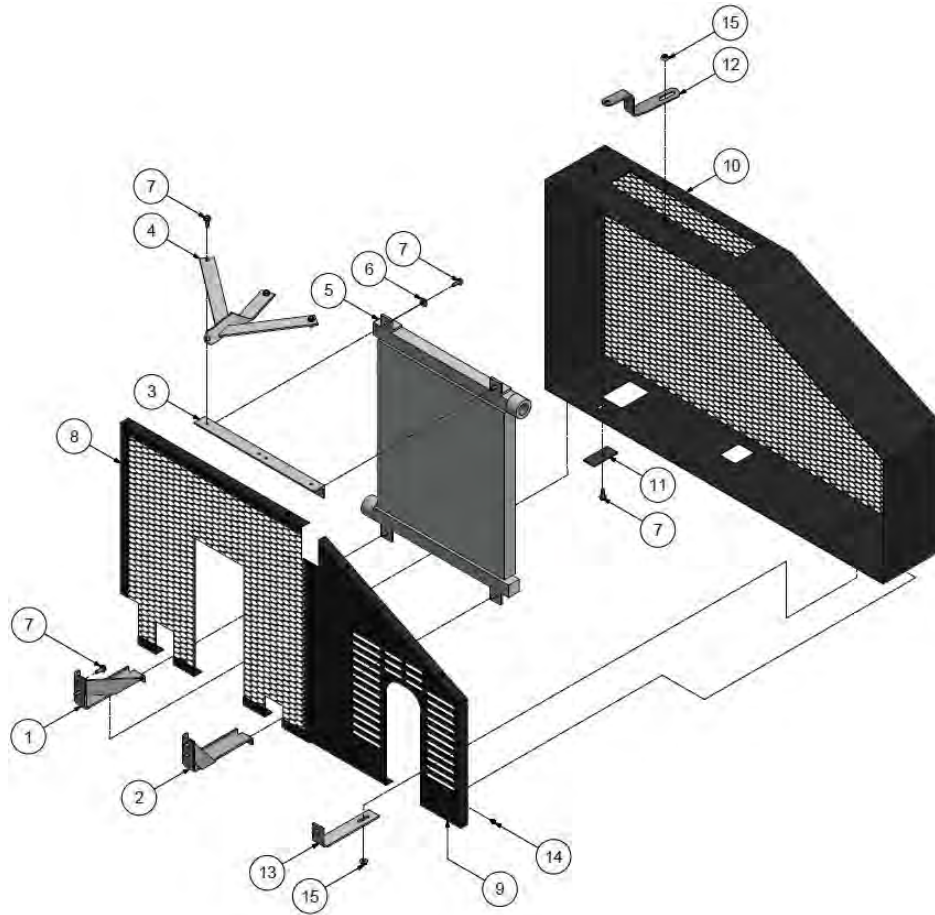

439CAS810-00  
Ref Drawing

**BELTGUARD - WITH AFTERCOOLER**

**401CAS4029**

Item	Part Number	Description	Qty
1	P09960B	BRACKET	1
2	P09961B	BRACKET	1
3	P09962B	BRACKET	1
4	P09964B	BRACKET	1
5	P09954A	AFTERCOOLER	1
6	M3056	WASHER	4
7	M1454	SCREW	13
8	P09971C	BELTGUARD, BACK-PUMP END	1
9	P09972C	BELTGUARD, BACK-MOTOR END	1
10	P09973C	BELTGUARD, FRONT	1
11	M1368	PLATE	1
12	M1536	BRACKET	1
13	P04567A	BRACKET	1
14	M1683	SCREW	14
15	M3485	NUT	2
16	P04365A	TRIM (NOT SHOWN)	4 FT

### Discharge Piping – Simplex Horizontal, Standard

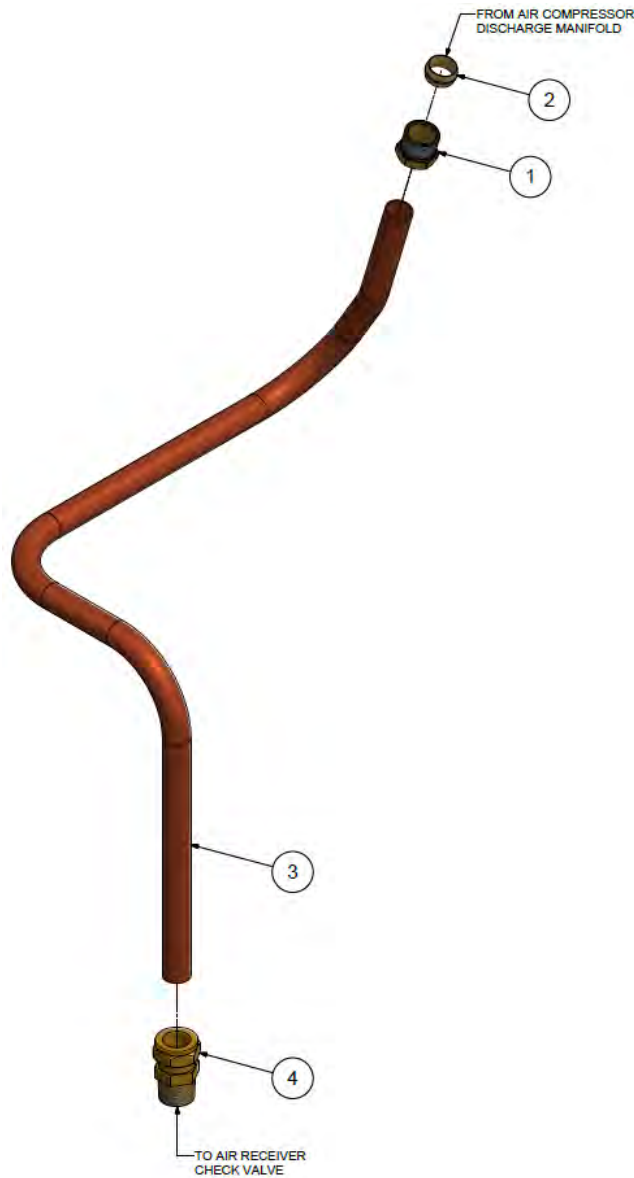

440CAS810-00  
Ref Drawing

#### DISCHARGE PIPING - 120/240GL HORIZONTAL, STANDARD

409CAS4022

Item	Part Number	Description	Qty
1	M1418	COMPRESSION NUT	1
2	P06064A	COMPRESSION FERRULE	1
3	TEN010238	DISCHARGE TUBE	1
4	P03591A	COMPRESSION FITTING, STRAIGHT	1

#### DISCHARGE PIPING – BASE MOUNT, STANDARD

426CAS4022

Item	Part Number	Description	Qty
1	M1418	COMPRESSION NUT	1
2	P06064A	COMPRESSION FERRULE	1

### Discharge Piping – Simplex Horizontal, with Aftercooler (optional)

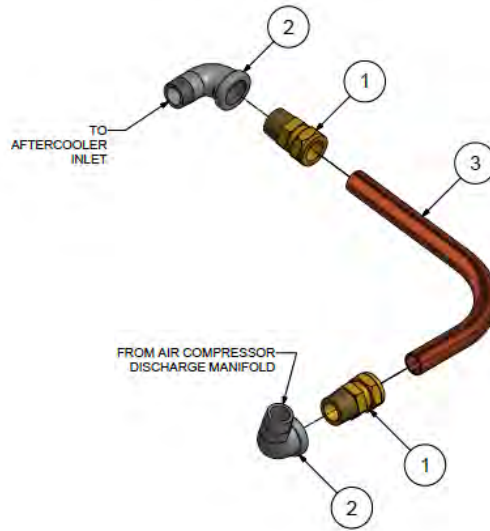

441CAS810-00  
Ref Drawing

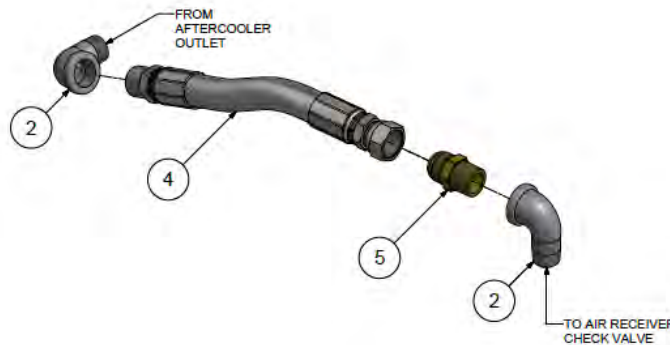

#### DISCHARGE PIPING - 120/240GL HORIZONTAL, AFTERCOOLER

403CAS4022

Item	Part Number	Description	Qty
1	P03591A	COMPRESSION FITTING, STRAIGHT	2
2	M983B	PIPE ELBOW	4
3	P05253B	DISCHARGE TUBE	1
4	VP1019924	HOSE ASSEMBLY	1
5	P04300A	HOSE ADAPTER	1

#### DISCHARGE PIPING - BASE MOUNT, AFTERCOOLER

427CAS4022

Item	Part Number	Description	Qty
1	P03591A	COMPRESSION FITTING, STRAIGHT	2
2	M983B	PIPE ELBOW	2
3	P05253B	DISCHARGE TUBE	1

### Discharge Piping – Duplex Horizontal, Standard

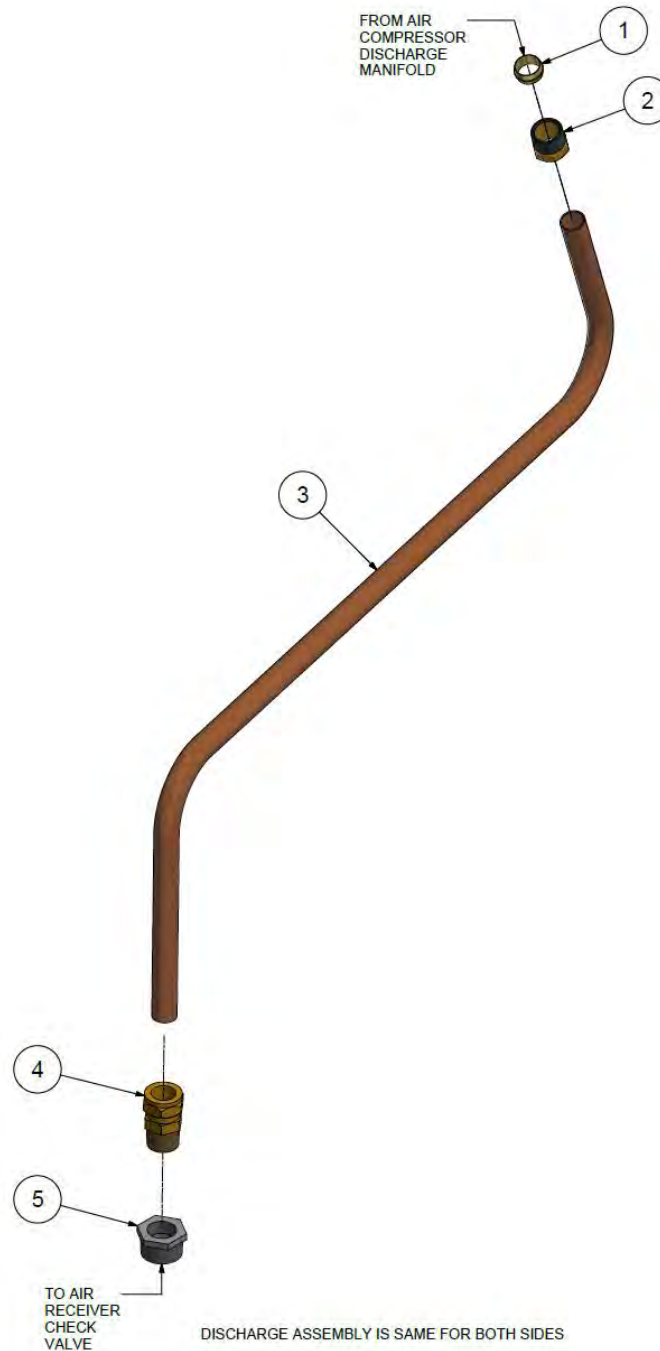

407CAD810-00  
Ref Drawing

**DISCHARGE PIPING - 240GL HORIZONTAL, STANDARD**

**411CAD4022**

Item	Part Number	Description	Qty
1	P06064A	COMPRESSION FERRULE	1
2	M1418	COMPRESSION NUT	1
3	CC1072236	DISCHARGE TUBE	1
4	P03591A	COMPRESSION FITTING, STRAIGHT	1
5	M954B	BUSHING	1

### Discharge Piping – Duplex Horizontal, with Aftercooler (optional)

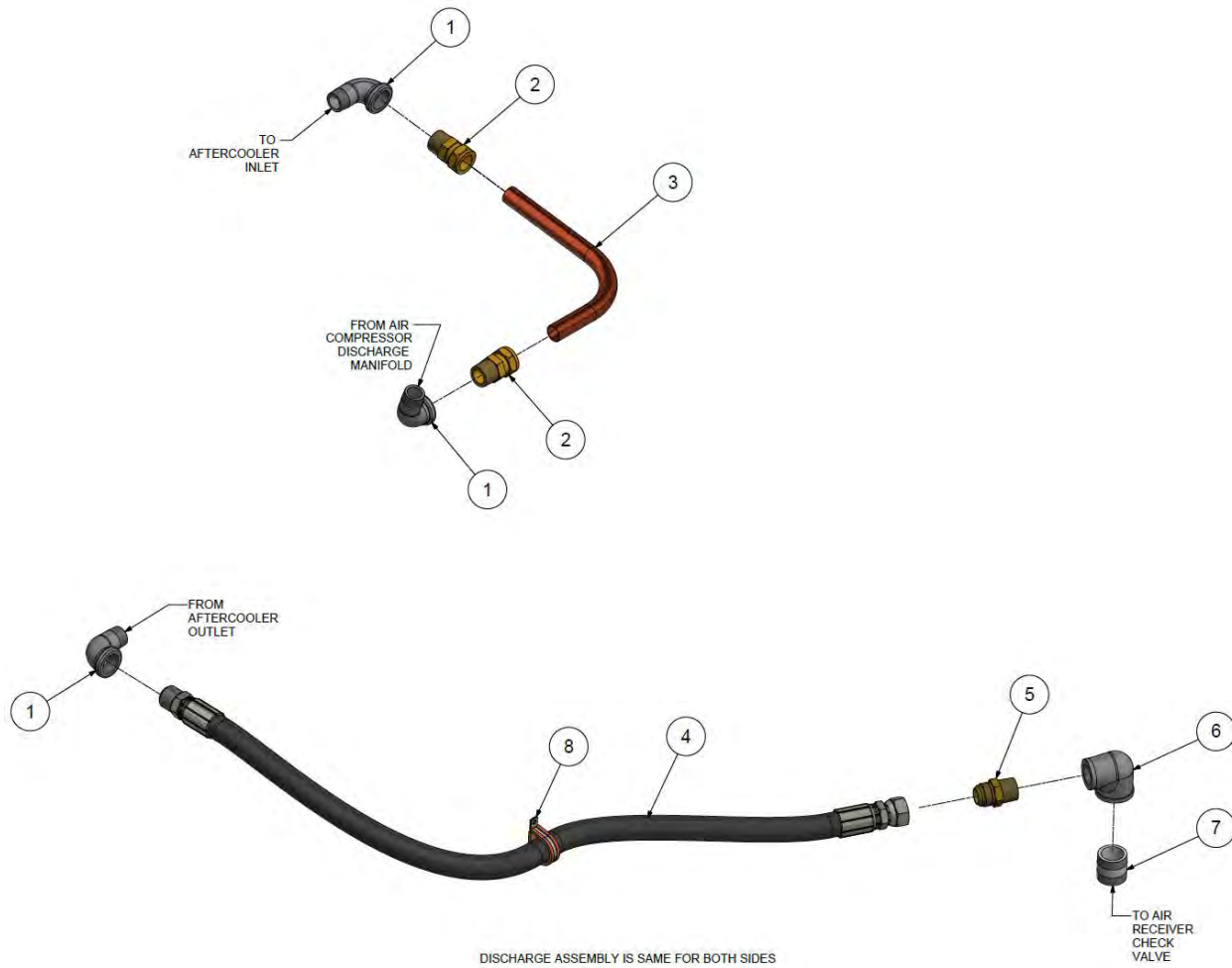

408CADS810-00  
Ref Drawing

#### DISCHARGE PIPING - 240GL HORIZONTAL, AFTERCOOLER

412CAD4022

Item	Part Number	Description	Qty
1	M983B	PIPE ELBOW	3
2	P03591A	COMPRESSION FITTING, STRAIGHT	2
3	P05253B	DISCHARGE TUBE	1
4	VP1019925	HOSE ASSEMBLY	1
5	P04300A	HOSE ADAPTER	1
6	M2358	PIPE ELBOW, REDUCER	1
7	M1039B	PIPE NIPPLE	1
8	P08874A	CLAMP	1







# **CHAMPION**

For additional information, contact your local representative or visit:  
[www.championpneumatic.com/contactus.aspx](http://www.championpneumatic.com/contactus.aspx)

©2019 Gardner Denver, Inc. Printed in U.S.A.



Please recycle after use.