

CHAMPION

R-SERIES

Air Compressors & Units

R-70 PARTS LIST MANUAL

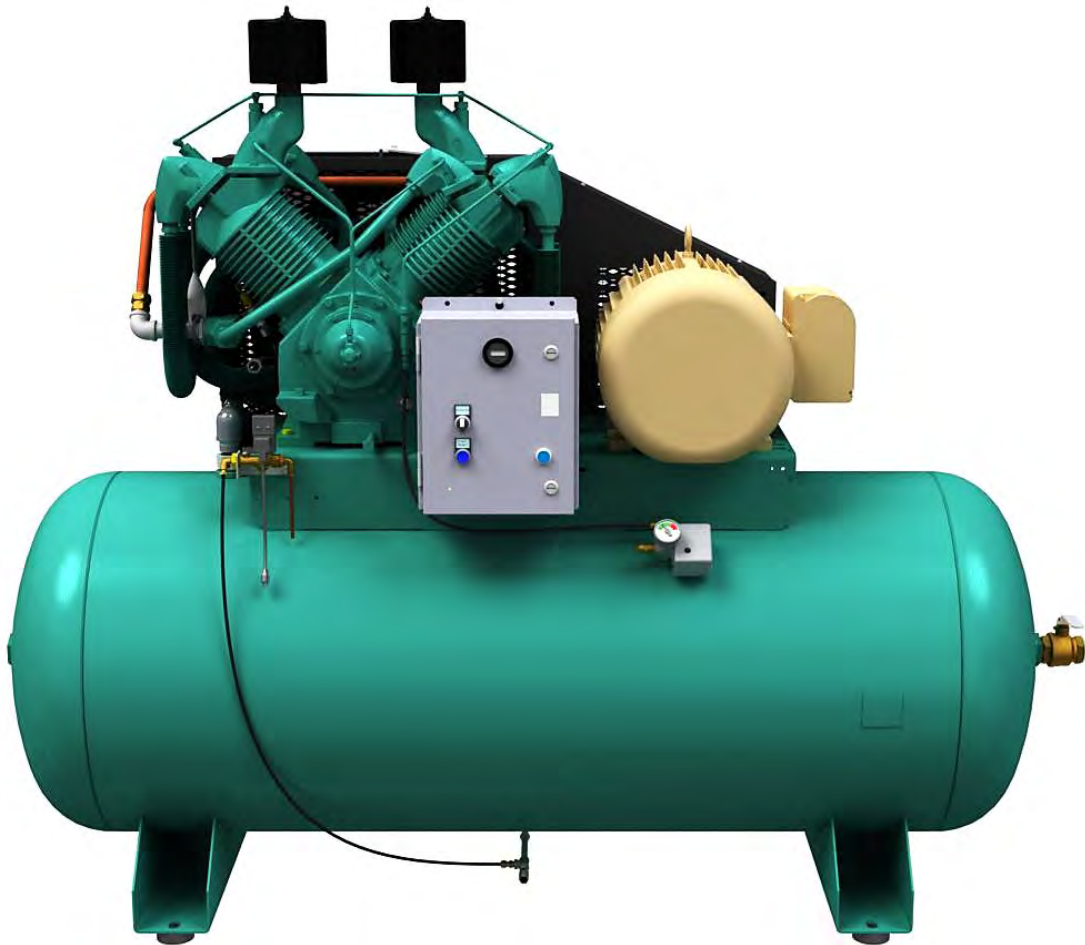

REFER TO THE R-SERIES OPERATION & SERVICE MANUAL FOR IMPORTANT SAFETY INFORMATION. READ, UNDERSTAND AND RETAIN ALL INSTRUCTIONS BEFORE OPERATING OR SERVICING THIS EQUIPMENT TO PREVENT INJURY OR EQUIPMENT DAMAGE.

**MAINTAIN COMPRESSOR RELIABILITY AND PERFORMANCE WITH
GENUINE CHAMPION® COMPRESSOR
PARTS AND SUPPORT SERVICES**

Champion® Compressor genuine parts, manufactured to design tolerances, are developed for optimum dependability – specifically for Champion compressor systems. Design and material innovations are the result of years of experience with hundreds of different compressor applications. Reliability in materials and quality assurance are incorporated in our genuine replacement parts.

Your authorized Champion Compressor distributor offers all the backup you'll need. A worldwide network of authorized distributors provides the finest product support in the air compressor industry.

Your authorized distributor can support your Champion air compressor with these services:

1. Trained parts specialists to assist you in selecting the correct replacement parts.
2. A full line of factory tested CHAMPLUB™ compressor lubricants specifically formulated for use in Champion compressors.
3. Repair and maintenance kits designed with the necessary parts to simplify servicing your compressor.

Authorized distributor service technicians are factory trained and skilled in compressor maintenance and repair. They are ready to respond and assist you by providing fast, expert maintenance and repair services.

To Contact Champion or locate your local distributor:

Visit: www.championpneumatic.com

Or

Call: (888)436-5499

INSTRUCTIONS FOR ORDERING REPAIR PARTS

When ordering parts, specify Compressor MODEL, HORSEPOWER and SERIAL NUMBER (see nameplate on unit). All orders for Parts should be placed with the nearest authorized distributor.

Order by part number and description. Reference numbers are for your convenience only.

Table of Contents

Section 1 – General 5

 Dimensions..... 5

 Specifications 5

 Performance 5

Section 2 – Compressor 6

 Crankcase Group..... 6

 Crankshaft Group..... 7

 Centrifugal Unloader Group..... 8

 Piston/Rod Group – Low Pressure 10

 Piston/Rod Group – High Pressure 12

 Cylinder Group – Standard..... 14

 Cylinder Group – with Head Unloaders (optional) 16

 Tubing and Control Group – Standard 18

 Tubing and Control Group – with Head Unloaders (optional)..... 20

 High Temperature Switch (optional) 22

 Filter Maintenance Indicator (optional)..... 22

 Low Oil Shutdown Control (optional) 23

Section 3 – Electric Packages 24

 Horizontal Package – Simplex 24

 Horizontal Package – Duplex 26

 Electric Motor List 28

 Tank Drain – Manual 29

 Tank Drain – Electric (optional)..... 30

 Control Group – Simplex Start/Stop 31

 Control Group – Simplex Dual Control (optional)..... 32

Table of Contents

Control Group – Duplex Start/Stop.....	33
Control Group – Duplex Dual Control (optional)	34
Power Transmission	35
Belt Guard – Standard.....	36
Belt Guard – with Aftercooler (optional)	37
Discharge Piping – Simplex Horizontal, Standard	38
Discharge Piping – Simplex Horizontal, with Aftercooler (optional)	39
Discharge Piping – Duplex Horizontal, Standard	40
Discharge Piping – Duplex Horizontal, with Aftercooler (optional).....	41
Notes.....	42

Section 1 – General

Dimensions

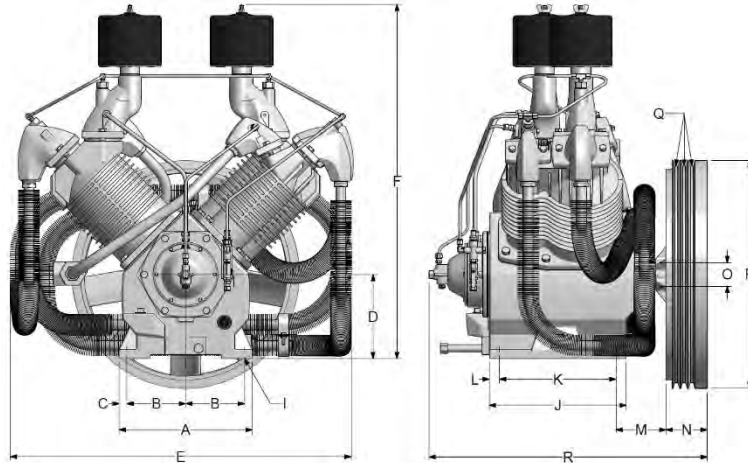

C325-C
Ref Drawing

Item	R10D
A	Base-Width 12-7/8"
B	Bolt Down-Width 5-11/16"
C	Bolt Down to Edge 3/4"
D	Base to Crank Ctr 8-3/16"
E	Overall Width 33"
F	Overall Height 34-3/16"
I	Bolt Down Hole Dia. 9/16"
J	Base-Depth 13-1/4"
K	Bolt Down Depth 11-1/4"
L	Bolt Down to Edge 1"
M	Bolt Hole to Wheel (Max.) 5-3/4"
N	Flywheel Width 3-1/2"
O	Crank Diameter 2-1/4"
P	Flywheel Diameter 22"
Q	Flywheel Grooves 3VB
R	Overall Depth 27-1/4"

- H.P. Exhaust Opening: 1-1/4" NPT
- Flywheel Rotation – Clockwise when viewed from front, flywheel to rear.

Specifications

BORE & STROKE (INCHES)	NO. OF CYLINDERS	OIL CAP. (QTS.)	WEIGHT (LBS)	PRESSURE (PSIG)	CU FT./REV.	MIN./MAX. RPM
6-1/4 & 3-1/4 x 4	4	6-1/3	450	175	.142	425/1000

Performance

OUTPUT PRESS. PSIG	MOTOR H.P.	PUMP RPM	DISPL. CFM	COOLING AIR FLOW CFM	HEAT REJECTION BTU/HR	APPROX. PULLEY O.D. INCHES
125	20	715	101.5	2395	44,700	8.95
175	20	665	94.4	2227	44,700	8.35
125	25	919	130.5	3078	55,970	11.40
175	25	782	111.0	2619	55,970	9.75
125	30	919	130.5	3078	67,160	11.4
175	30	919	130.5	3078	67,160	11.4

All data is based on 1800 RPM electric motors as a power source.

Pulley Dia. (approx.) = $\frac{\text{Compressor RPM} \times \text{Flywheel Dia.}}{\text{Motor or Engine RPM}}$

Section 2 – Compressor

Crankcase Group

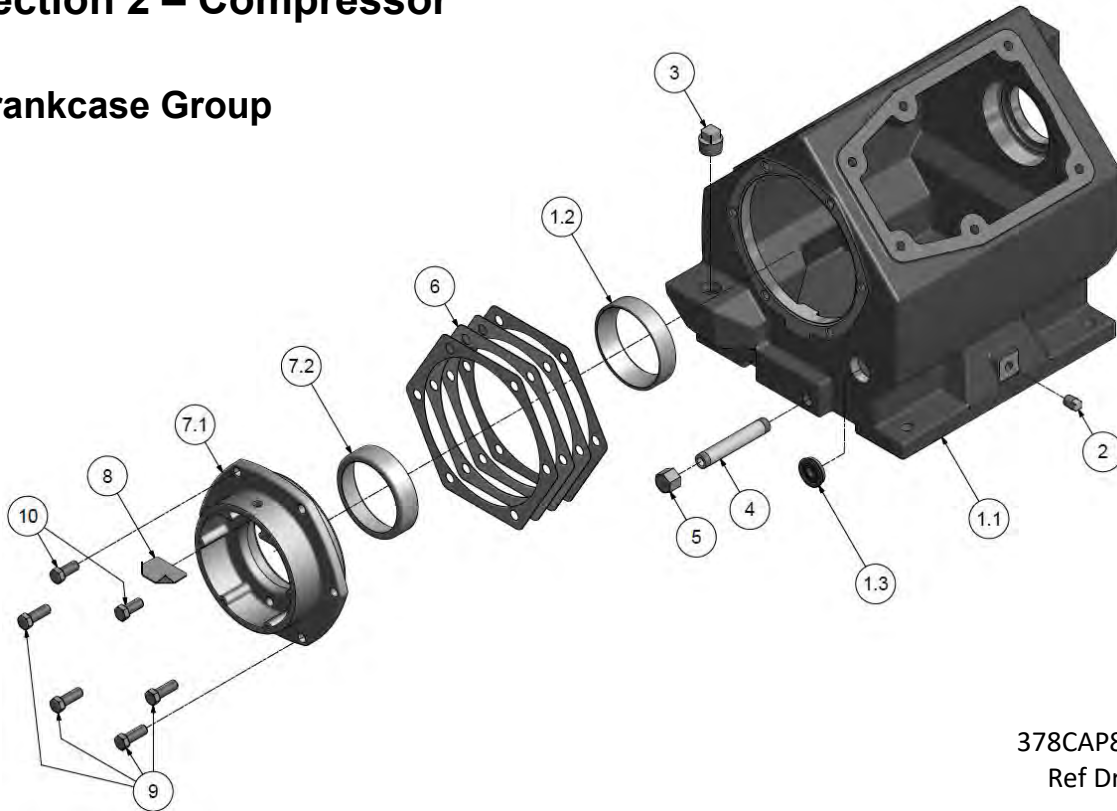

378CAP810-01
Ref Drawing

CRANKCASE GROUP

304CAP013

Item	Part Number	Description	Qty
1.1	M1386	CRANKCASE	1
1.2	P03431A1*	MAIN BEARING, CUP	1
1.3	RE714	OIL LEVEL GAUGE	1
2	64AA5	PLUG	1
3	64A5	PLUG	1
4	M492	NIPPLE	1
5	M461	CAP	1
6	M1398*	GASKET, .032	1
6	M1399*	GASKET, .015	1
6	M1400*	GASKET, .010	1
6	M1401*	GASKET, .006	1
7.1	P12274C	GOVERNOR HOUSING	1
7.2	P03431A1*	MAIN BEARING, CUP	1
8	P12381A	PLATE, GOVERNOR BAFFLE	1
9	M2345	SCREW (torque @ 550 in-lbs)	4
10	M2597	SCREW (torque @ 550 in-lbs)	2

*not sold separately – see repair parts

REPAIR PARTS

Item	Part Number	Description	Qty
1.2,7.2	Z6506	MAIN BEARING	2
6	Z775	GOVERNOR HOUSING GASKET SET	1
-	Z10889	COMPRESSOR GASKET SET (excludes valve gaskets)	1

Crankshaft Group

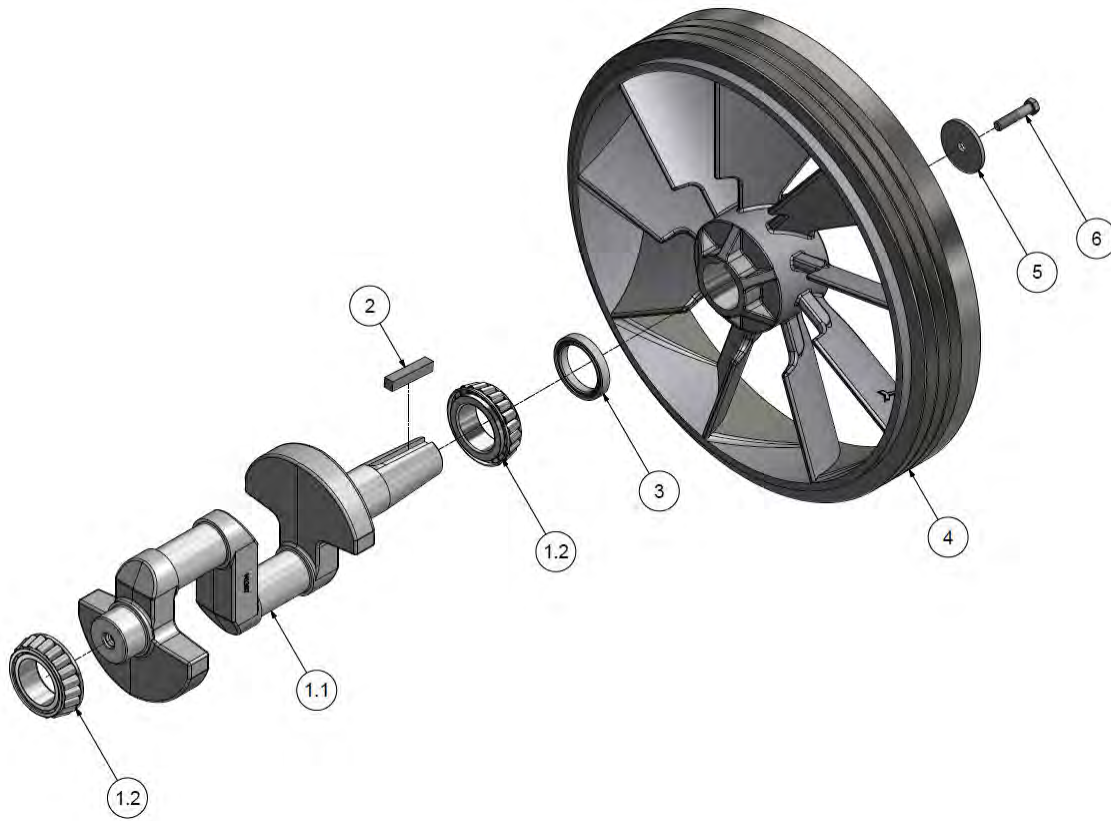

379CAP810-01
Ref Drawing

CRANKSHAFT GROUP

304CAP004

Item	Part Number	Description	Qty
1.1	M1387	CRANKSHAFT	1
1.2	P03431A2*	MAIN BEARING, CONE & ROLLER	2
2	M1506	KEY	1
3	P03433A	OIL SEAL	1
4	P05723C	FLYWHEEL	1
5	M1394	WASHER	1
6	M2265	SCREW (torque @ 600 in-lbs)	1

*not sold separately – see repair parts

REPAIR PARTS

Item	Part Number	Description	Qty
1.2	Z6506	MAIN BEARING	2

Centrifugal Unloader Group

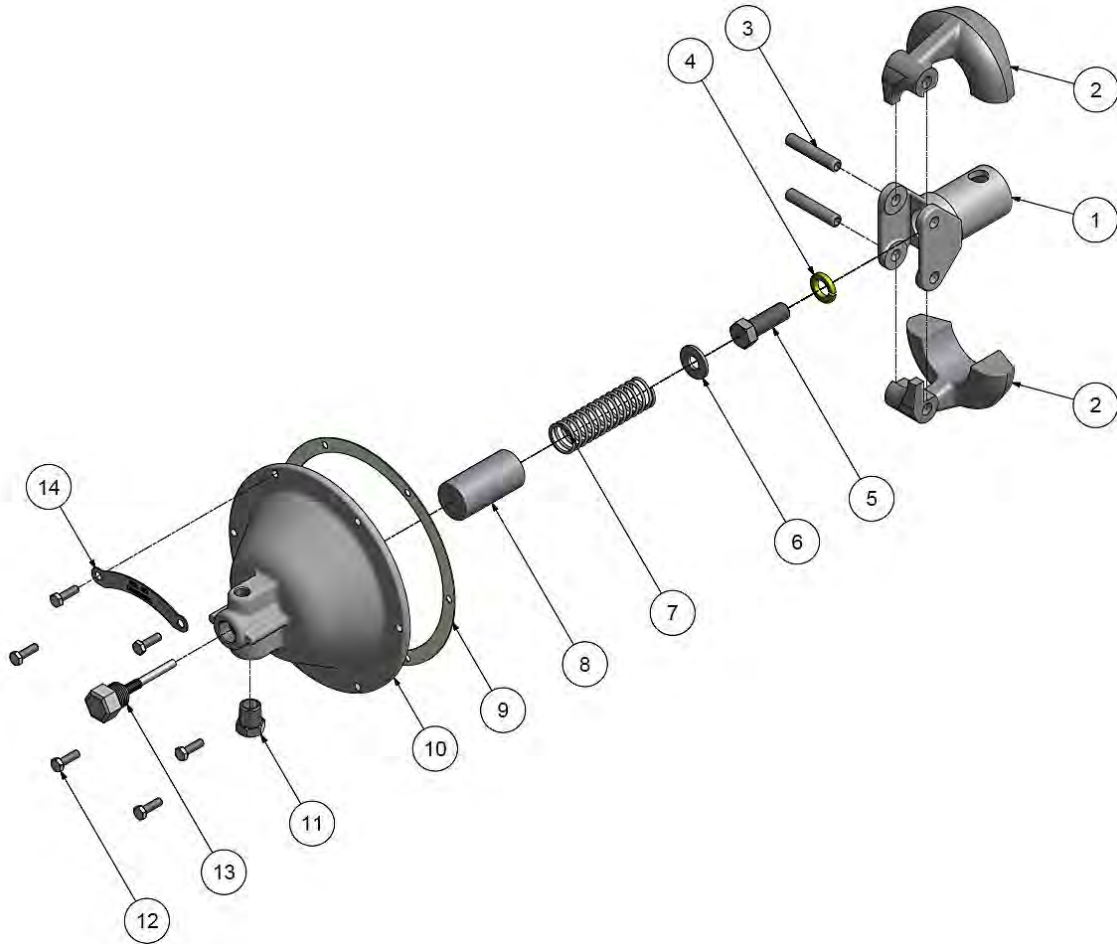

352CAP810-01
Ref Drawing

Centrifugal Unloader Group

CENTRIFUGAL UNLOADER GROUP

300CAP890

Item	Part Number	Description	Qty
1	SE583B	SPINDLE,GOVERNOR	1
2	SE582B	WEIGHT,GOVERNOR	2
3	SE592A	PIN, GOVERNOR WEIGHT	2
4	95B4Z	WASHER-LOCK	1
5	M2345	SCREW (torque @ 470 in-lbs)	1
6	M912A	SPACER,CENTRIFUGAL UNLOADER	1
7	SE590	SPRING,GOVERNOR	1
8	SE587	SLEEVE, SPRING	1
9	SE1489	GASKET,GOVERNOR COVER	1
10	TEN010354	GOVERNOR HOUSING COVER	1
11	TEN013303	BREATHER	1
12	M3473	SCREW (torque @ 60 in-lbs)	6
13	Z12414A	RELEASE VALVE KIT	1
14	M3658	SERIAL NUMBER PLATE	1

REPAIR PARTS

Item	Part Number	Description	Qty
-	Z764	COMPRESSOR GASKET SET (excludes valve gaskets)	1

Piston/Rod Group – Low Pressure

(2 per compressor)

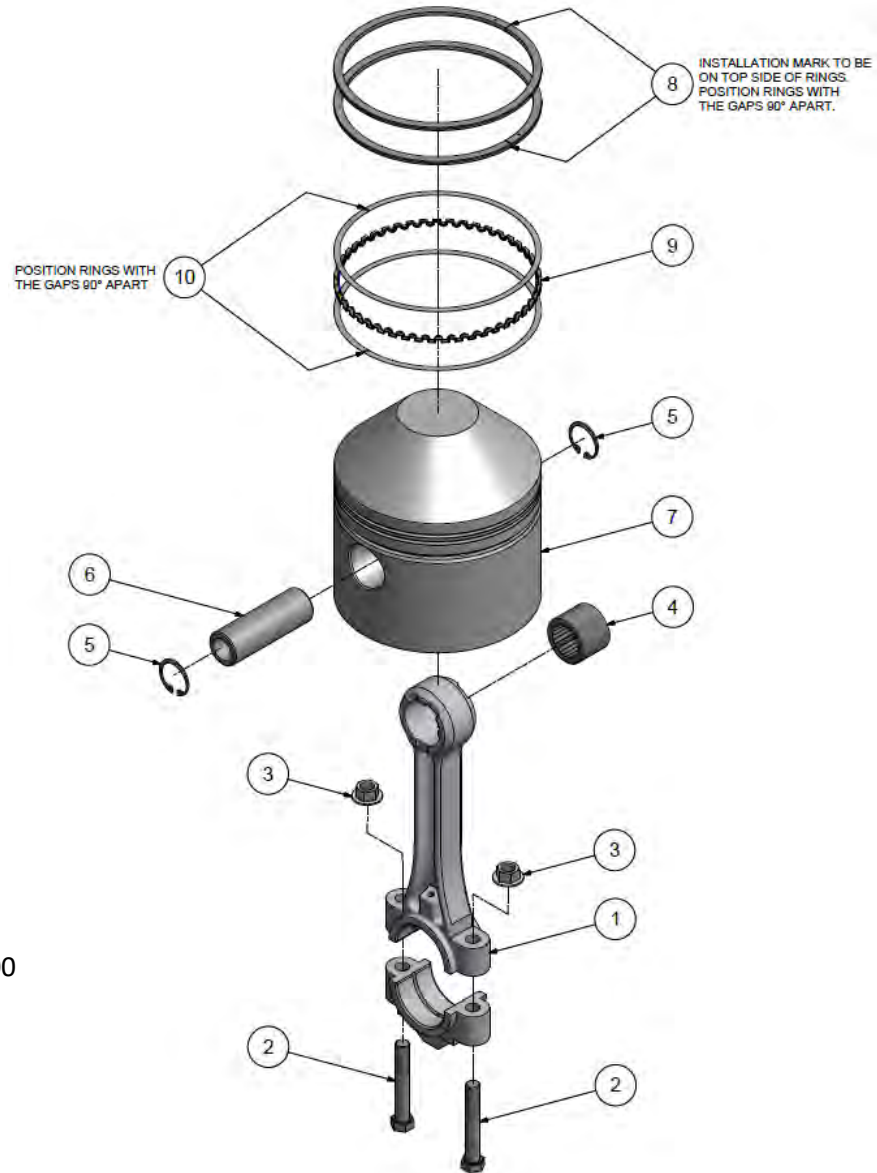

367CAP810-00
Ref Drawing

Piston/Rod Group – Low Pressure

(2 per compressor)

LOW PRESSURE ROD/PISTON GROUP

308CAP4056

Item	Part Number	Description	Qty
1	M1384*	CONNECTING ROD	1
2	P03458A	SCREW (torque @ 400 in-lbs)	2
3	P03459A	NUT	2
4	P03430A	BEARING,WRIST PIN	1
5	P03434A	RING,RETAINING	2
6	M1395	PIN,PISTON	1
7	M1906	PISTON	1
8	P09498A*	RING,PISTON	2
9	P03946B1*	RING,EXPANDER	1
10	P03946B2*	RING,RAIL	2

*not sold separately – see repair parts

REPAIR PARTS

Item	Part Number	Description	Qty
1-4	Z621	CONNECTING ROD ASSEMBLY KIT	1
5-7	ZM1906	PISTON KIT, LOW PRESSURE WITH PIN	1
8-10	Z9087	RING SET, LOW PRESSURE	1
5-10	Z9108	PISTON & RING KIT, LOW PRESSURE	1
-	Z9123	COMPLETE RING SET, HIGH & LOW PRESSURE x 2	1

Piston/Rod Group – High Pressure

(2 per compressor)

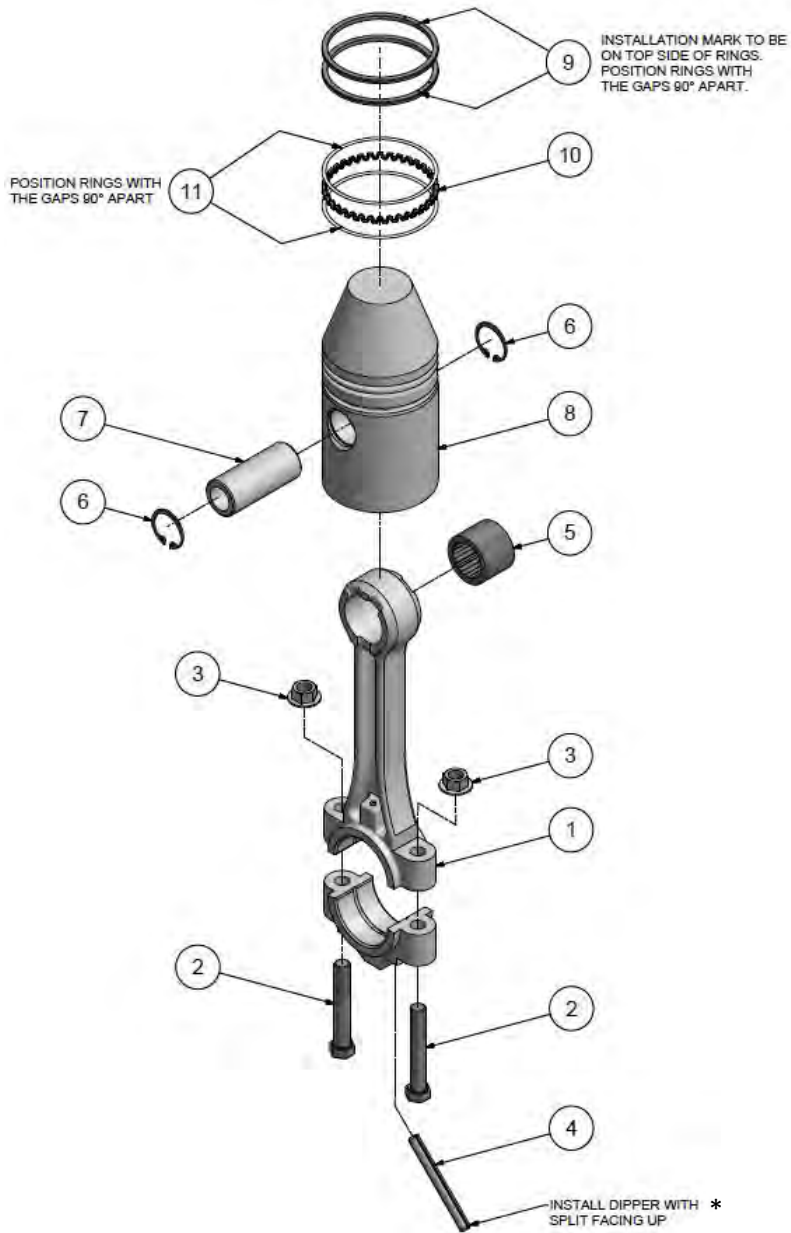

366CAP810-00
Ref Drawing

* ORIENT ROD ON CRANKSHAFT SO THAT THE SPLIT EDGE IS FACING THE DIRECTION OF TRAVEL THROUGH LUBRICANT

Piston/Rod Group – High Pressure

(2 per compressor)

HIGH PRESSURE ROD/PISTON GROUP

307CAP4056

Item	Part Number	Description	Qty
1	M1384*	CONNECTING ROD	1
2	P03458A	SCREW (torque @ 400 in-lbs)	2
3	P03459A	NUT	2
4	P03440A	OIL DIPPER	1
5	P03430A	BEARING,WRIST PIN	1
6	P03434A	RING,RETAINING	2
7	M1383	PIN,PISTON	1
8	M1393	PISTON	1
9	P03427A*	RING,PISTON	2
10	P03428B1*	RING,EXPANDER	1
11	P03428B2*	RING,RAIL	2

*not sold separately – see repair parts

REPAIR PARTS

Item	Part Number	Description	Qty
1-5	Z622	CONNECTING ROD ASSEMBLY KIT	1
6-8	ZM1393	PISTON KIT, HIGH PRESSURE WITH PIN	1
9-11	Z9088	RING SET, HIGH PRESSURE	1
6-11	Z9107	PISTON & RING KIT, HIGH PRESSURE	1
-	Z9123	COMPLETE RING SET, HIGH & LOW PRESSURE x 2	1

Cylinder Group – Standard

(2 per compressor)

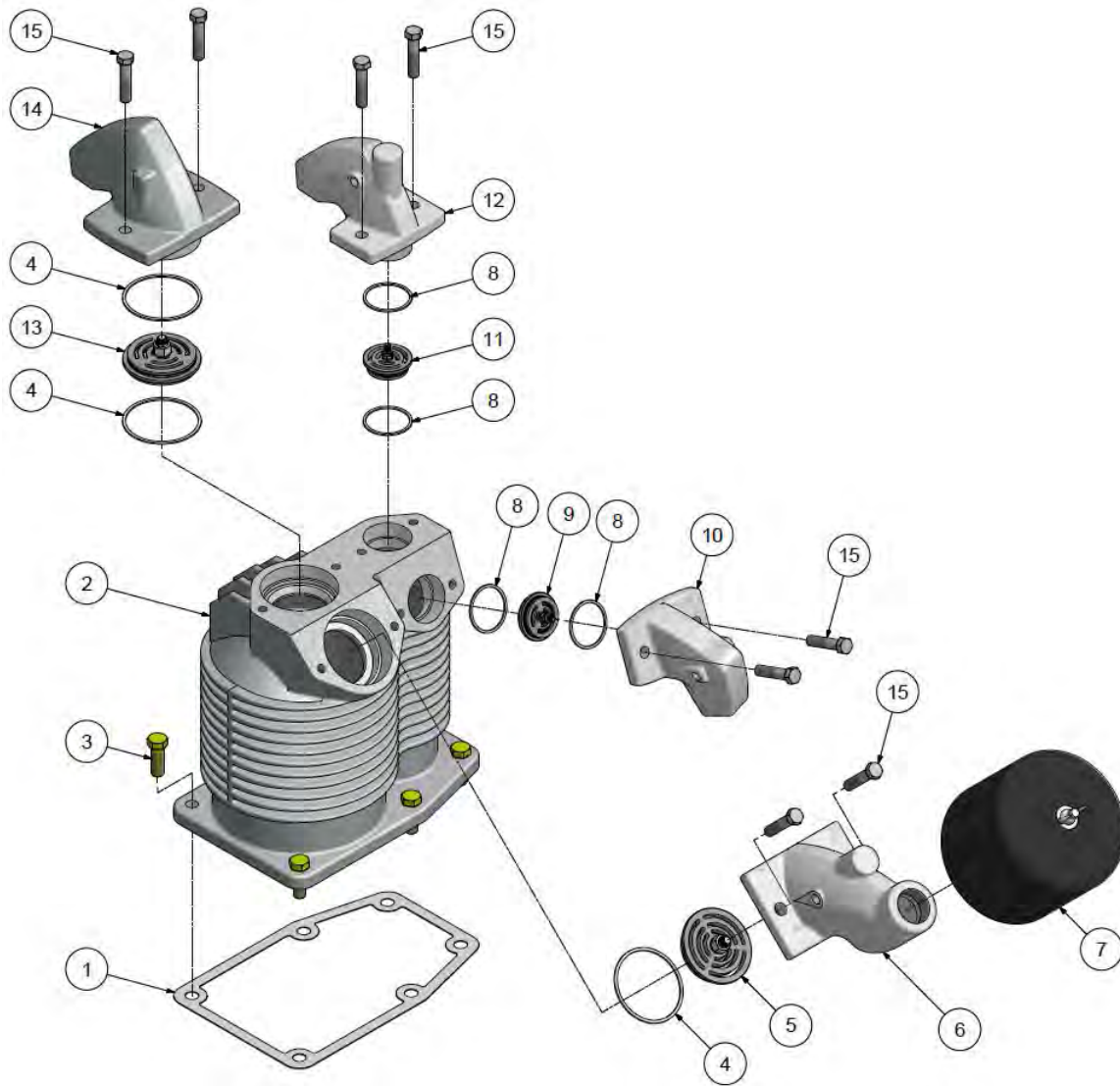

374CAP810-00
Ref Drawing

Cylinder Group – Standard

(2 per compressor)

CYLINDER GROUP

301CAP4042

Item	Part Number	Description	Qty
1	M1391	GASKET, CYLINDER FLANGE	1
2	P05863D	CYLINDER	1
3	M3461	SCREW (torque @ 900 in-lbs)	6
4	P07352A	GASKET,VALVE,LP,ALUMINUM	3
5	P03436A	VALVE,LP,INTAKE	1
6	P09711D	MANIFOLD,LP INTAKE	1
7	P07447A	FILTER SILENCER	1
8	P07353A	GASKET,VALVE,HP,ALUMINUM	4
9	P04815A	VALVE,HP,EXHAUST	1
10	M1508	MANIFOLD,HP EXHAUST	1
11	M2878	VALVE,HP,INTAKE	1
12	M1431	MANIFOLD,HP INTAKE	1
13	P03437A	VALVE,LP,EXHAUST	1
14	M1423	MANIFOLD,LP EXHAUST	1
15	P04779A	SCREW (torque @ 230 in-lbs)	8

REPAIR PARTS

Item	Part Number	Description	Qty
4, 5, 8, 9, 11, 13	Z656	COMPLETE VALVE SET, WITH GASKET SET	1
4, 8	Z657	COMPLETE VALVE GASKET SET	1
-	Z10888	COMPRESSOR GASKET SET (excludes valve gaskets)	1

Cylinder Group – with Head Unloaders (optional)

(2 per compressor)

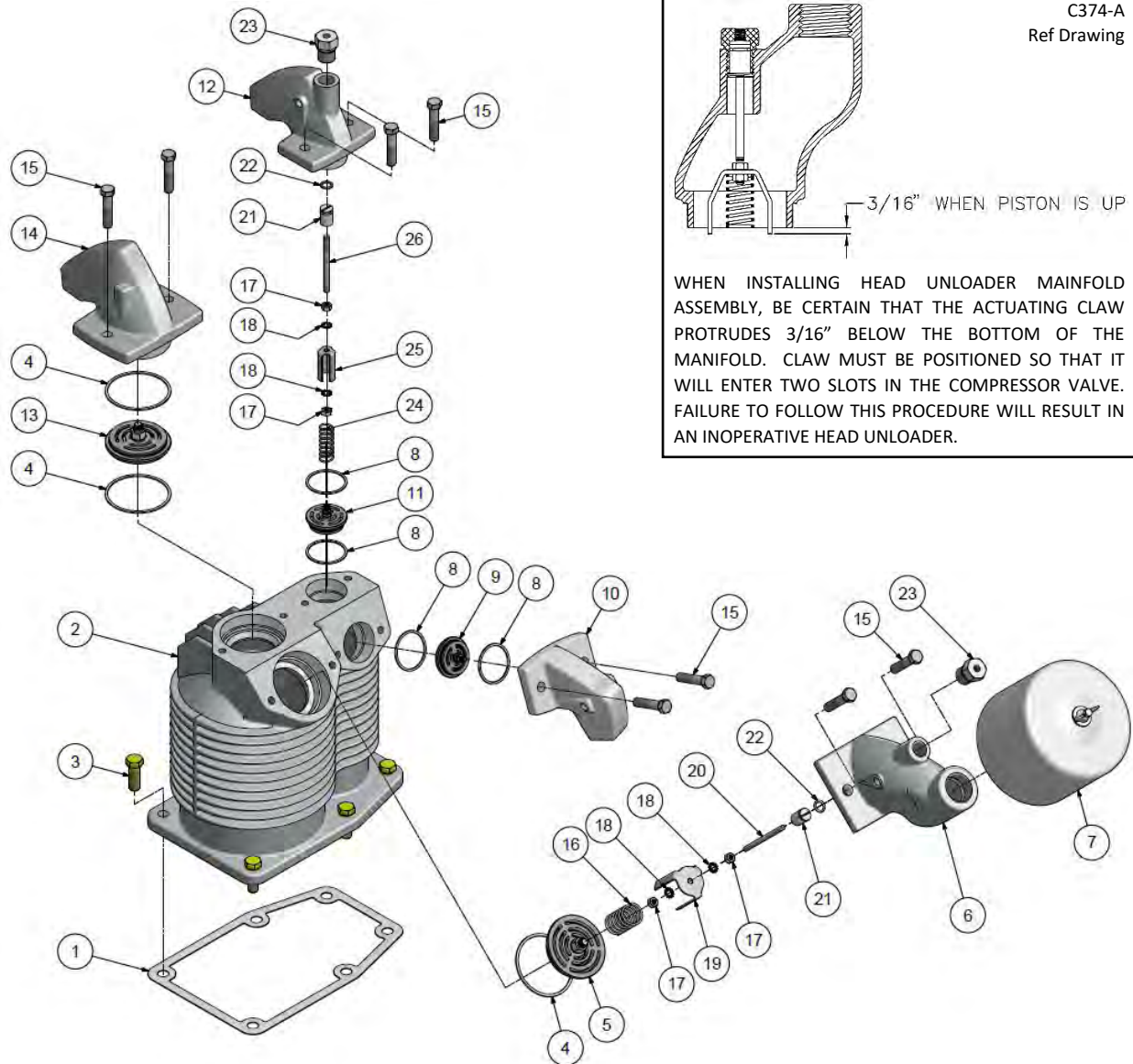

375CAP810-00
Ref Drawing

Cylinder Group – with Head Unloaders (optional)

(2 per compressor)

CYLINDER GROUP - HEAD UNLOADERS

303CAP4042

Item	Part Number	Description	Qty
1	M1391	GASKET, CYLINDER FLANGE	1
2	P05863D	CYLINDER	1
3	M3461	SCREW (torque @ 900 in-lbs)	6
4	P07352A	GASKET,VALVE,LP,ALUMINUM	3
5	P03436A	VALVE,LP,INTAKE	1
6	P09712D	MANIFOLD,LP INTAKE,HU	1
7	P07447A	FILTER SILENCER	1
8	P07353A	GASKET,VALVE,HP,ALUMINUM	4
9	P04815A	VALVE,HP,EXHAUST	1
10	M1508	MANIFOLD,HP EXHAUST	1
11	M2878	VALVE,HP,INTAKE	1
12	M1426	MANIFOLD,HP INTAKE, HU	1
13	P03437A	VALVE,LP,EXHAUST	1
14	M1423	MANIFOLD,LP EXHAUST	1
15	P04779A	SCREW (torque @ 230 in-lbs)	8
16	M1449	SPRING,LP	1
17	M926A	NUT	4
18	M919A	LOCK WASHER	4
19	M1815	UNLOADER FORK,LP	1
20	M1448	UNLOADER PISTON ROD,LP	1
21	P02287A	UNLOADER PISTON	2
22	P02547A	O-RING	2
23	P02306B	UNLOADER VALVE CYLINDER	2
24	M1450	SPRING,HP	1
25	M1447	UNLOADER FORK,HP	1
26	M1452	UNLOADER PISTON ROD,HP	1

REPAIR PARTS

Item	Part Number	Description	Qty
4, 5, 8, 9, 11, 13	Z656	COMPLETE VALVE SET, WITH GASKET SET	1
4, 8	Z657	COMPLETE VALVE GASKET SET	1
-	Z10888	COMPRESSOR GASKET SET (excludes valve gaskets)	1
-	HUK503	KIT, HEAD UNLOADER CONVERSION (includes manifolds, unloader valves assemblies, pilot valve, fittings and tubing)	1

Tubing and Control Group – Standard

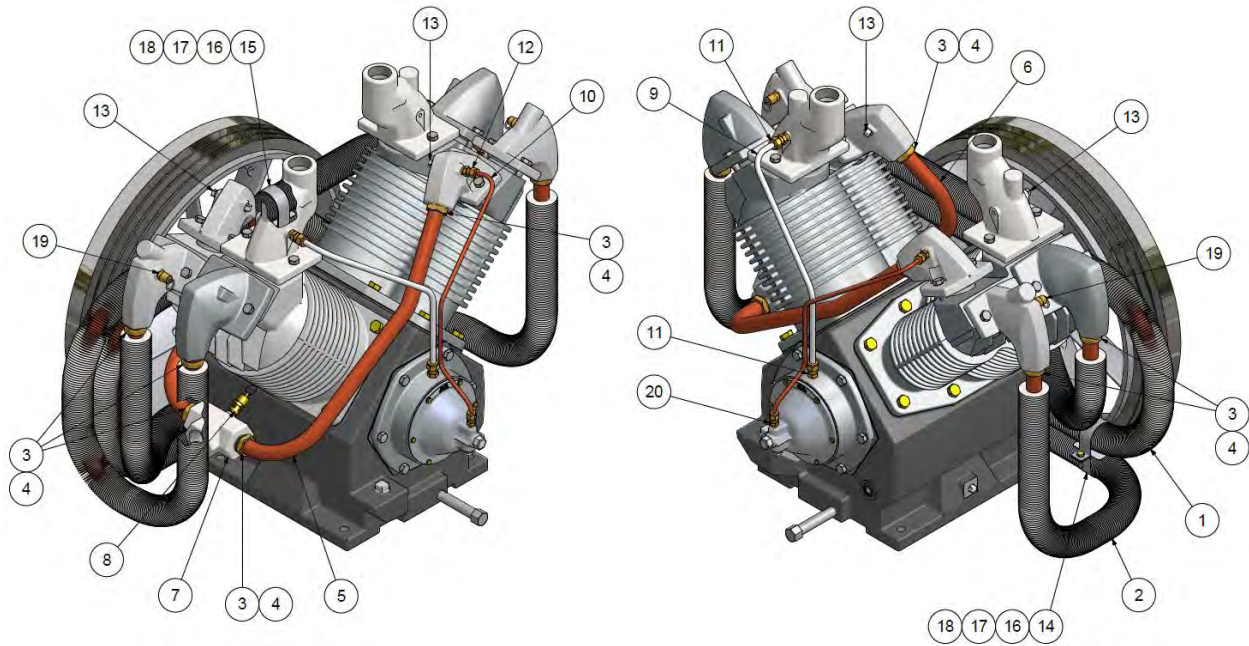

380CAP810-00
Ref Drawing

Tubing and Control Group – Standard

TUBING & CONTROL GROUP			306CAP272
Item	Part Number	Description	Qty
1	M1432	INTERCOOLER, LEFT	1
2	M1433	INTERCOOLER, RIGHT	1
3	M1418	COMPRESSION NUT	8
4	P06064A	COMPRESSION FERRULE	8
5	M1532	DISCHARGE TUBE, RIGHT	1
6	M1533	DISCHARGE TUBE, LEFT	1
7	M1516	EXHUAUST MANIFOLD TEE	1
8	P09704A	PRESSURE RELIEF VALVE, 270 PSIG	1
9	M1420	BREATHER TUBE	1
10	305CAP294	RELEASE VALVE TUBE	1
11	M2864	COMPRESSION FITTING, STRAIGHT	2
12	M2862	COMPRESSION FITTING, STRAIGHT	1
13	64AA5	PIPE PLUG	4
14	M1537	INTERCOOLER CLAMP (Lower)	1
15	M1538	INTERCOOLER CLAMP (Upper)	1
16	P05012A	CLIP	2
17	M3471	SCREW	2
18	M3424	NUT	2
19	M3685	PRESSURE RELIEF VALVE, 75 PSIG	2
20	M2863	COMPRESSION FITTING, STRAIGHT	1

Tubing and Control Group – with Head Unloaders (optional)

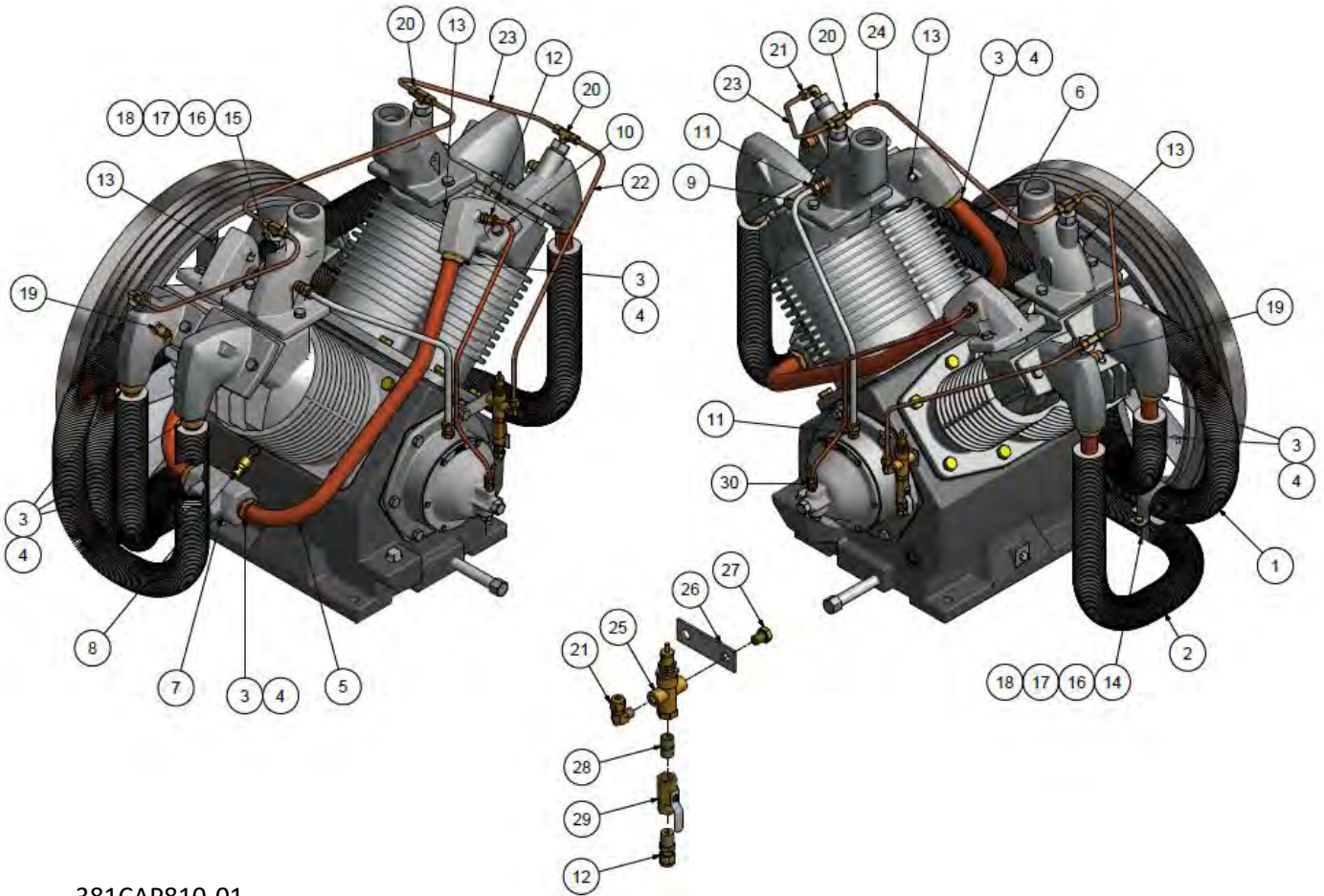

381CAP810-01
Ref Drawing

Tubing and Control Group – with Head Unloaders (optional)

TUBING & CONTROL GROUP - HEAD UNLOADERS

307CAP272

Item	Part Number	Description	Qty
1	M1432	INTERCOOLER, LEFT	1
2	M1433	INTERCOOLER, RIGHT	1
3	M1418	COMPRESSION NUT	8
4	P06064A	COMPRESSION FERRULE	8
5	M1532	DISCHARGE TUBE, RIGHT	1
6	M1533	DISCHARGE TUBE, LEFT	1
7	M1516	EXHUAUST MANIFOLD TEE	1
8	P09704A	PRESSURE RELIEF VALVE, 270 PSIG	1
9	M1420	BREATHER TUBE	1
10	305CAP294	RELEASE VALVE TUBE	1
11	M2864	COMPRESSION FITTING, STRAIGHT	2
12	M2862	COMPRESSION FITTING, STRAIGHT	2
13	64AA5	PIPE PLUG	4
14	M1537	INTERCOOLER CLAMP (Lower)	1
15	M1538	INTERCOOLER CLAMP (Upper)	1
16	P05012A	CLIP	2
17	M3471	SCREW	2
18	M3424	NUT	2
19	M3685	PRESSURE RELIEF VALVE, 75 PSIG	2
20	M2879	COMPRESSION FITTING, TEE	3
21	M2868	COMPRESSION FITTING, ELBOW	2
22	CC1059015	UNLOADER ACTUATING TUBE	1
23	CC1061685	UNLOADER MANIFOLD TUBE	2
24	CC1061684	UNLOADER MANIFOLD TUBE	1
25	M2854	PILOT VALVE 90-120# (125 psi discharge)	1
25	M2853	PILOT VALVE 140-170# (175 psi discharge)	1
26	M807	BRACKET,PILOT VALVE MOUNTING	1
27	M3465	SCREW	1
28	63Z15	PIPE NIPPLE	1
29	VP1022988	BALL VALVE	1
30	M2863	COMPRESSION FITTING, STRAIGHT	1

REPAIR PARTS

Item	Part Number	Description	Qty
-	HUK504	KIT, HEAD UNLOADER CONVERSION (includes manifolds, unloader valves assemblies, pilot valve, fittings and tubing)	1

High Temperature Switch (optional)



TEN008394-01
Ref Drawing

HIGH TEMPERATURE SWITCH

TEN008394

Item	Part Number	Description	Qty
1	TEN001792	SWITCH, HIGH TEMP, 450F	1
2	003FE98	CORD GRIP	1
3	TEN008088	SEALING RING	1
4	TEN008089	LOCK NUT	1
5	M1003B	PIPE TEE	1
6	P08798A	PIPE NIPPLE	1

Filter Maintenance Indicator (optional)

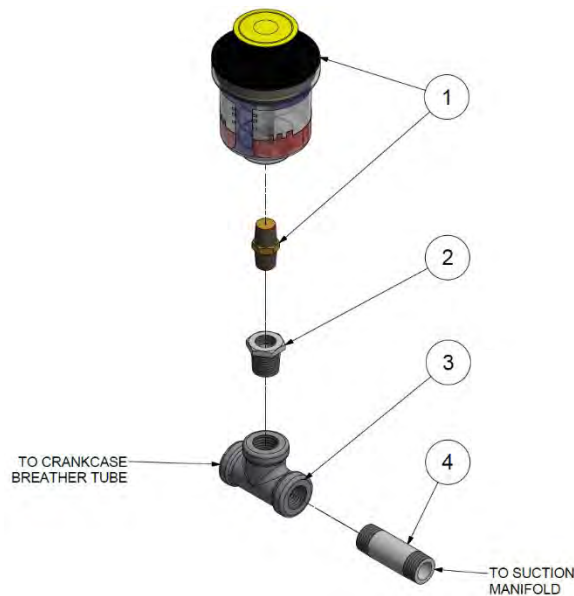

FILTER MAINTENANCE INDICATOR

TEN013353

Item	Part Number	Description	Qty
1	P11683A	FILTER INDICATOR	1
2	64E44	PIPE BUSHING	1
3	M1003B	PIPE TEE	1
4	M1016B	PIPE NIPPLE	1

Low Oil Shutdown Control (optional)

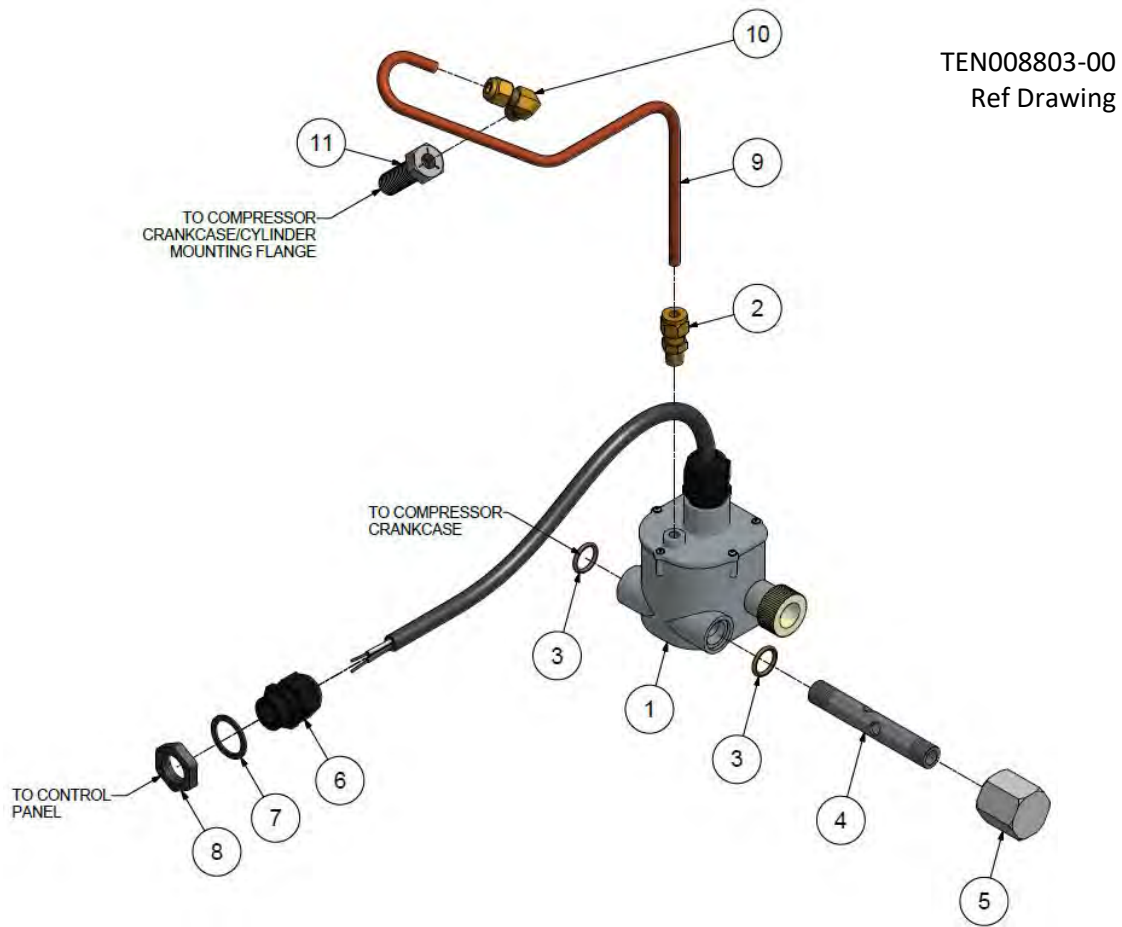

LOW OIL SHUTDOWN CONTROL

TEN008803

Item	Part Number	Description	Qty
1	TEN008741	SWITCH-LOW OIL SHUTDOWN CONTROL	1
2	M2863	COMPRESSION FITTING, STRAIGHT	1
3	2009222	O-RING	2
4	CC1153304	OIL TUBE	1
5	LO30	RETAINER CAP	1
6	003FE98	CORD GRIP	1
7	TEN008088	SEALING RING	1
8	TEN008089	LOCK NUT	1
9	CC1007632	VENT TUBE	1
10	M2868	COMPRESSION FITTING, ELBOW	1
11	M1500	VENT FITTING	1

REPAIR PARTS

Item	Part Number	Description	Qty
1-11	TEN008809	KIT-LOSC w/CABLE, COMPLETE	1
1-4	TEN008855	KIT-LOSC w/CABLE, REPLACEMENT	1

Section 3 – Electric Packages

Horizontal Package – Simplex

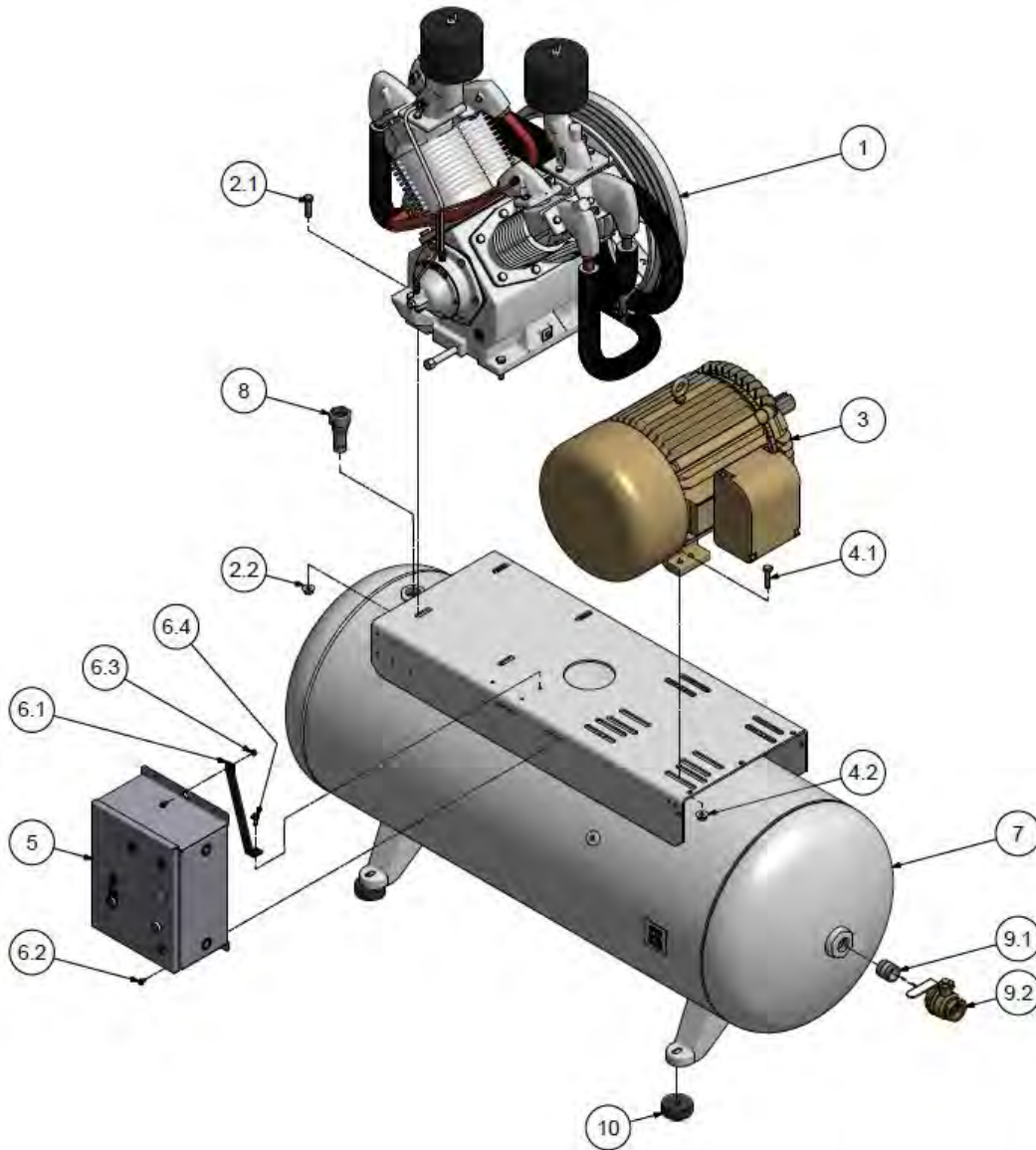

442CAS810-00
Ref Drawing

Horizontal Package – Simplex

Item	Part Number	Description	Qty
COMPRESSOR			R2-30A
1	R2-30A-P13	R70 COMPRESSOR	1
1	R2-30A-P10	R70 COMPRESSOR W/HEAD UNLOADERS	1
COMPRESSOR MOUNTING			403CAS4017
2.1	M3470	SCREW	4
2.2	M3486	NUT	4
MOTOR			
3	-	SEE MOTOR PART NUMBER LISTING ON FOLLOWING PAGE	1
MOTOR MOUNTING			403CAS4015
4.1	M3470	SCREW	4
4.2	M3486	NUT	4
SIMPLEX CONTROL PANEL			
5	-	SEE PART NUMBER LISTING IN CONTROL PANEL MANUAL	1
PANEL MOUNTING (HORIZONTAL)			
6.1	TEN008120	BRACKET-PANEL,120-240GL HORIZONTAL	1
6.1	TEN008121	BRACKET-PANEL,120-240GL HORIZ (25/30HP 208/230V)	1
6.2	M3349	SCREW	3
6.3	50AW3	NUT	1
6.4	M1454	SCREW	1
HORIZONTAL AIR RECEIVER / BASE MOUNT			
7	TEN005640	RECEIVER, 120 GALLON HORIZONTAL, 200PSI	1
7	TEN007574	RECEIVER, 240 GALLON HORIZONTAL, 200PSI	1
7	P03538C	BASE MOUNT PLATE (NOT SHOWN)	1
CHECK VALVE			
8	P03590A	VALVE,CHECK,INTANK,1-1/4"	1
BALL VALVE			406CAS4061
9.1	M1039B	PIPE NIPPLE	1
9.2	M2688	BALL VALVE	1
VIBRATION ISOLATORS (OPTIONAL)			
10	P14608A	ISOLATOR,VIBRATION,4"DIA.	4

Horizontal Package – Duplex

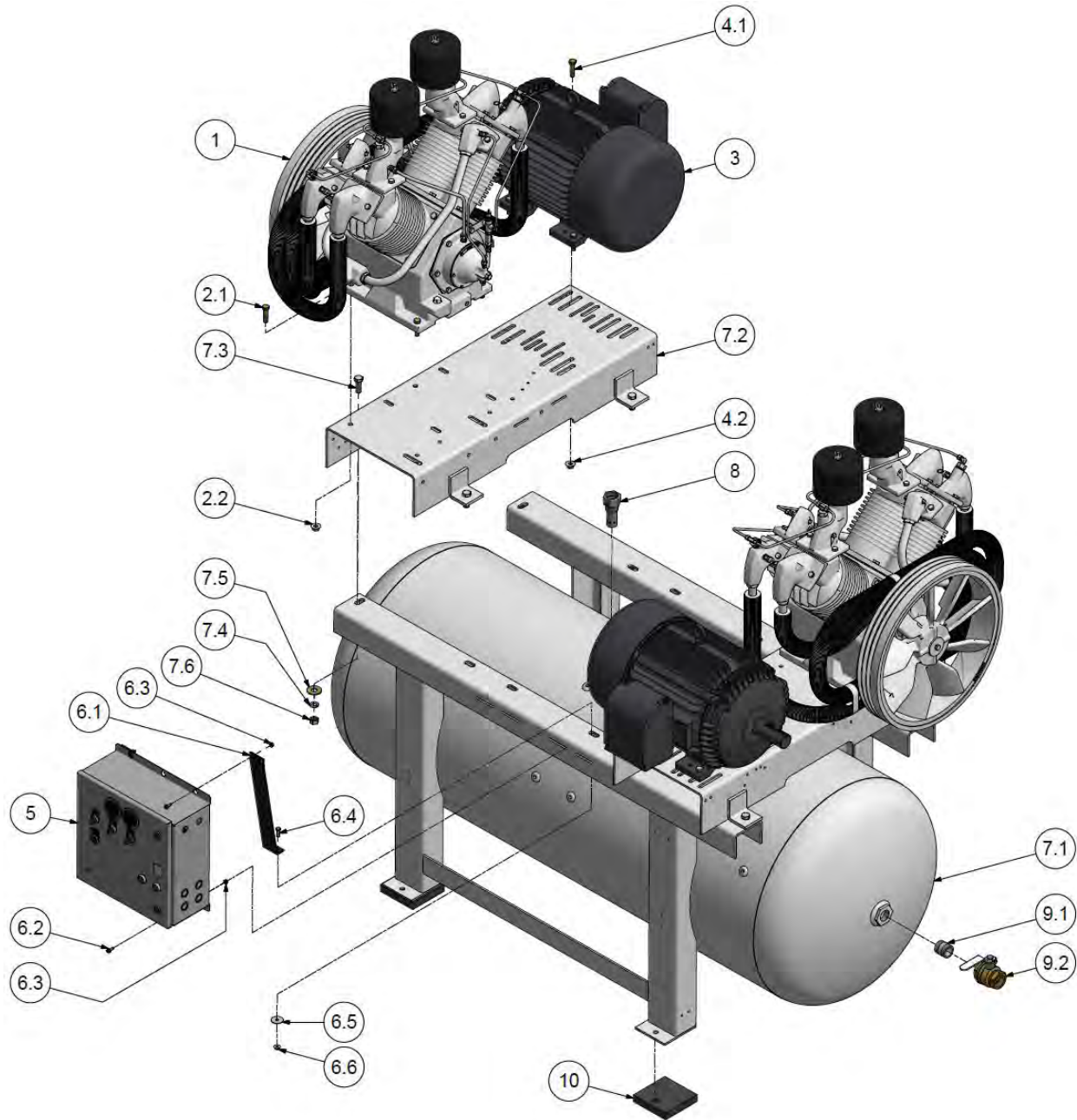

425CAD810-00
Ref Drawing

Horizontal Package – Duplex

Item	Part Number	Description	Qty
COMPRESSOR			R2-30A
1	R2-30A-P13	R70 COMPRESSOR	2
1	R2-30A-P10	R70 COMPRESSOR W/HEAD UNLOADERS	2
COMPRESSOR MOUNTING			403CAS4017
2.1	M3470	SCREW	8
2.2	M3486	NUT	8
MOTOR			
3	-	SEE MOTOR PART NUMBER LISTING ON FOLLOWING PAGE	2
MOTOR MOUNTING			403CAS4015
4.1	M3470	SCREW	4
4.2	M3486	NUT	4
DUPLEX CONTROL PANEL			
5	-	SEE PART NUMBER LISTING IN CONTROL PANEL MANUAL	1
PANEL MOUNTING			
6.1	TEN018265	BRACKET-PANEL	2
6.2	M1998	SCREW	4
6.3	50AW3	NUT	4
6.4	M1454	SCREW	2
6.5	95A32Z	WASHER	2
6.6	M3485	NUT	2
HORIZONTAL AIR RECEIVER			
7.1	P12127D	RECEIVER, 240 GALLON HORIZONTAL, 200PSI	1
7.2	P03538C	BASE PLATE	2
7.3	655EF070	SCREW	8
7.4	M1663	LOCK WASHER	8
7.5	M1276	FLAT WASHER	8
7.6	M1662	NUT	8
CHECK VALVE			
8.2	P03590A	CHECK VALVE	1
BALL VALVE			406CAS4061
9.1	M1039B	PIPE NIPPLE	1
9.2	M2688	BALL VALVE	1
VIBRATION ISOLATORS (OPTIONAL)			
10	300CAD365	ISOLATOR,VIBRATION,5.5" SQUARE	4

Electric Motor List

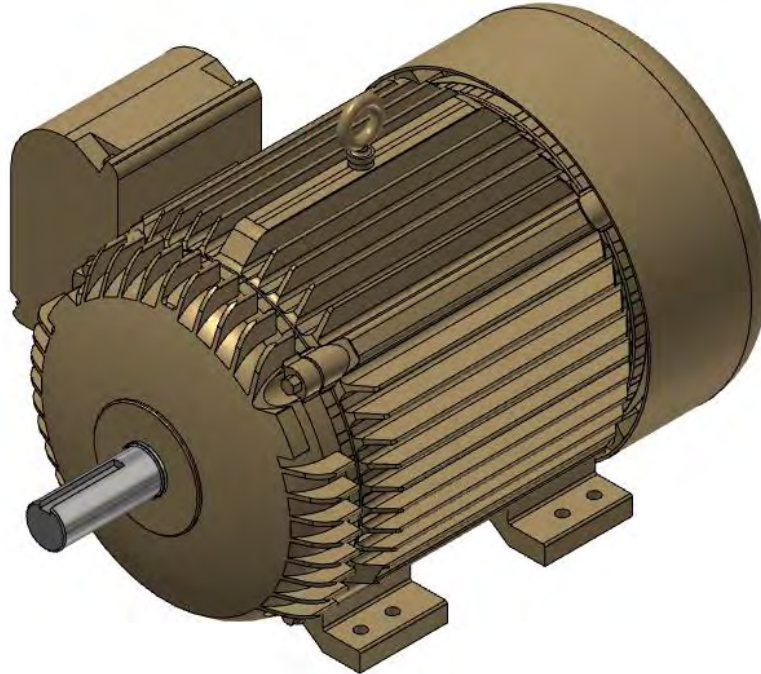

MOTORS

R2-30A

Item	Part Number	Description	Qty
3	24CA6676	MOTOR 20HP 208V 60HZ 3PH ODP	1
3	24CA6678	MOTOR 20HP 208V 60HZ 3PH TEFC	1
3	24CA6679	MOTOR 20HP 230V-460V 60HZ 3PH ODP	1
3	24CA6680	MOTOR 20HP 230V-460V 60HZ 3PH TEFC	1
3	24CA6681	MOTOR 20HP 575V 60HZ 3PH ODP	1
3	24CA6682	MOTOR 20HP 575V 60HZ 3PH TEFC	1
3	24CA6684	MOTOR 25HP 208V 60HZ 3PH ODP	1
3	24CA6686	MOTOR 25HP 208V 60HZ 3PH TEFC	1
3	24CA6687	MOTOR 25HP 230V-460V 60HZ 3PH ODP	1
3	24CA6688	MOTOR 25HP 230V-460V 60HZ 3PH TEFC	1
3	24CA6689	MOTOR 25HP 575V 60HZ 3PH ODP	1
3	24CA6690	MOTOR 25HP 575V 60HZ 3PH TEFC	1
3	24CA6692	MOTOR 30HP 208V 60HZ 3PH ODP	1
3	24CA6694	MOTOR 30HP 208V 60HZ 3PH TEFC	1
3	24CA6695	MOTOR 30HP 230V-460V 60HZ 3PH ODP	1
3	24CA6696	MOTOR 30HP 230V-460V 60HZ 3PH TEFC	1
3	24CA6697	MOTOR 30HP 575V 60HZ 3PH ODP	1
3	24CA6698	MOTOR 30HP 575V 60HZ 3PH TEFC	1

Tank Drain – Manual

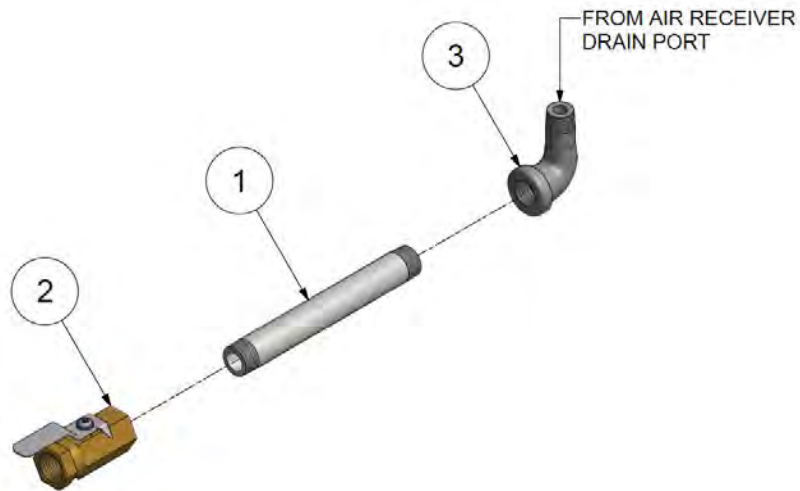

401CAS810-01
Ref Drawing

MANUAL TANK DRAIN (120 HORIZONTAL)

401CAS4027

Item	Part Number	Description	Qty
1	M1020B	PIPE NIPPLE, 8"	1
2	VP1022988	BALL VALVE	1
3	M980B	PIPE ELBOW	1
4	M1318 (NOT SHOWN)	PIPE BUSHING	1

Tank Drain – Electric (optional)

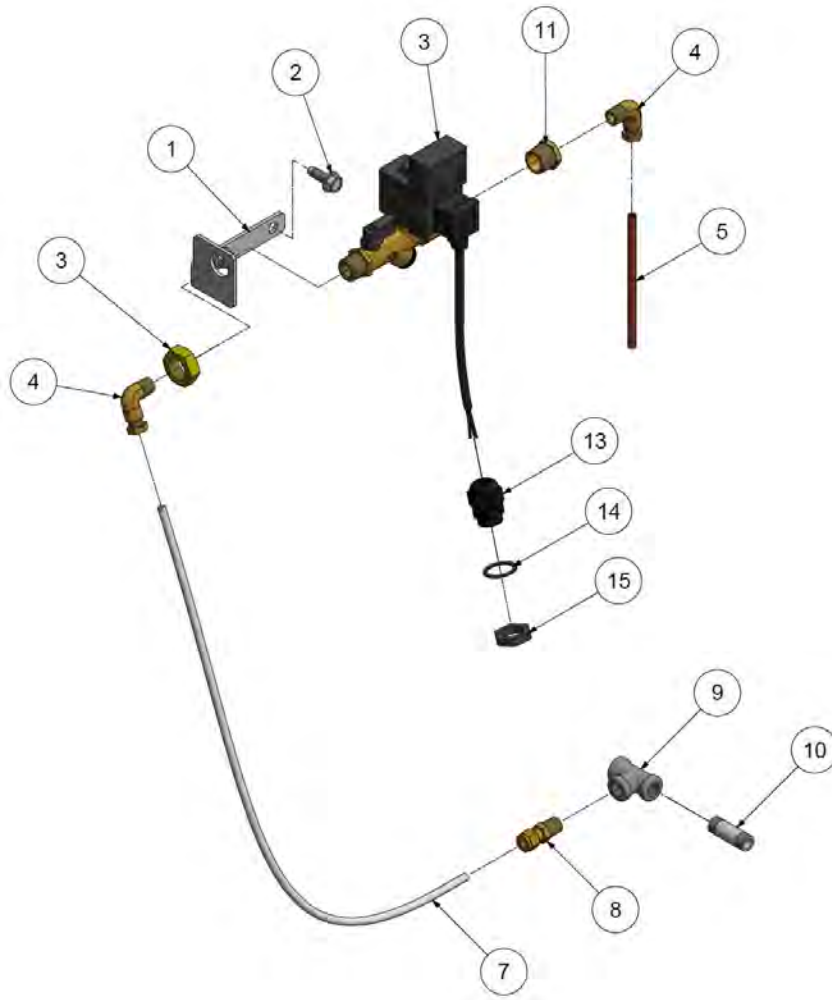

TEN002668-03
Ref Drawing

ELECTRIC TANK DRAIN

TEN002668

Item	Part Number	Description	Qty
1	CC1049403	BRACKET	1
2	M1454	SCREW	2
3	TEN001368	VALVE,ETD,W/STRAINER	1
4	86A40	COMPRESSION FITTING, ELBOW	2
5	M2471	COPPER TUBING	6 in
7	P08084A	PLASTIC TUBING	5 ft
8	M2862	COMPRESSION FITTING, STRAIGHT	1
9	M1003B	PIPE TEE	1
10	M1016B	PIPE NIPPLE	1
11	M3080	PIPE BUSHING	1
13	003FE98	CORD GRIP	1
14	TEN008088	SEALING RING	1
15	TEN008089	LOCK NUT	1

Control Group – Simplex Start/Stop

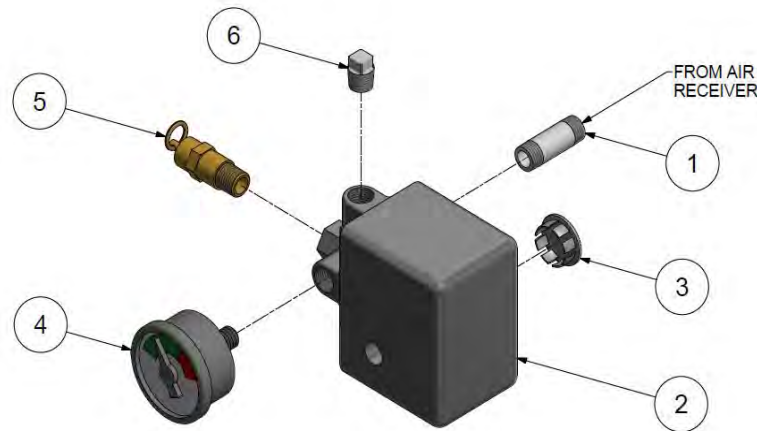

402CAS810-01
Ref Drawing
(Nema 1)

START/STOP CONTROL, NEMA 1

401CAS4052
403CAS4052

Item	Part Number	Description	Qty
1	M1016B	PIPE NIPPLE, 1.5"	1
2	P14205A	SWITCH,PRESSURE,95-125 (125 psi discharge)	1
2	P14202A	SWITCH,PRESSURE,140-175 (175 psi discharge)	1
3	M2352	KNOCKOUT HOLE PLUG	1
4	M519C	PRESSURE GAUGE	1
5	M2843	PRESSURE RELIEF VALVE, 200#	1
6	64AA5	PIPE PLUG	1

START/STOP CONTROL, NEMA 4

405CAS4052

Item	Part Number	Description	Qty
1	M1016B	PIPE NIPPLE, 1.5"	1
2	P07333A	SWITCH,PRESSURE,N4 (125 or 175 psi discharge)	1
4	M519C	PRESSURE GAUGE	1
5	M2843	PRESSURE RELIEF VALVE, 200#	1
-	64K1 (not shown)	PIPE CROSS	1

Control Group – Simplex Dual Control (optional)

408CAS810-02
 Ref Drawing
 (Nema 1)

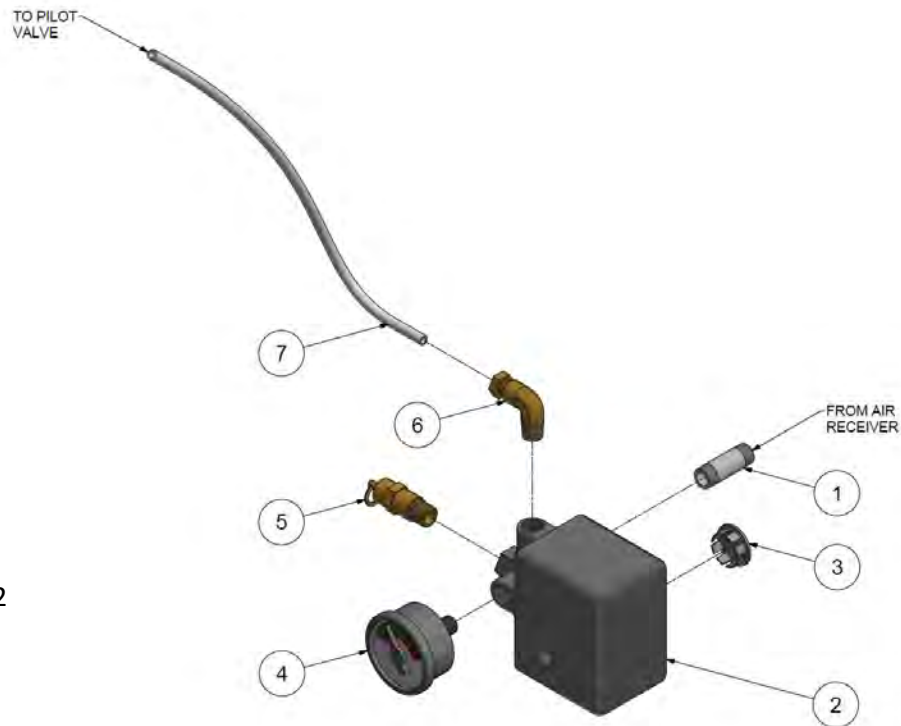

DUAL CONTROL, NEMA 1

407CAS4052
 411CAS4052

Item	Part Number	Description	Qty
1	M1016B	NIPPLE	1
2	P14205A	SWITCH,PRESSURE,95-125 (125 psi discharge)	1
2	P14202A	SWITCH,PRESSURE,140-175 (175 psi discharge)	1
3	M2352	KNOCKOUT HOLE PLUG	1
4	M519C	PRESSURE GAUGE	1
5	M2843	PRESSURE RELIEF VALVE, 200#	1
6	86A40	COMPRESSION FITTING, ELBOW	1
7	P08084A	PLASTIC TUBING	3.5 ft

DUAL CONTROL, NEMA 4

409CAS4052
 413CAS4052

Item	Part Number	Description	Qty
1	M1016B	NIPPLE	2
-	M1003B (not shown)	PIPE TEE	1
-	64K1 (not shown)	PIPE CROSS	1
2	P07333A	SWITCH,PRESSURE,N4 (125 or 175 psi discharge)	1
4	M519C	PRESSURE GAUGE	1
5	M2843	PRESSURE RELIEF VALVE, 200#	1
6	86A40	COMPRESSION FITTING, ELBOW	1
7	P08084A	PLASTIC TUBING	3 ft

Control Group – Duplex Start/Stop

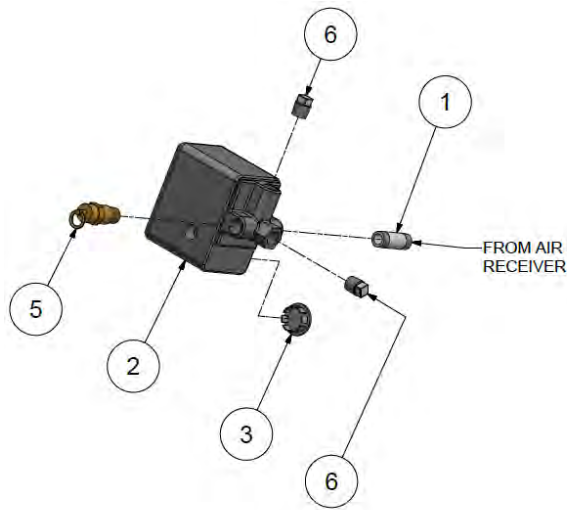

400CAD810-00
Ref Drawing
(Nema 1)

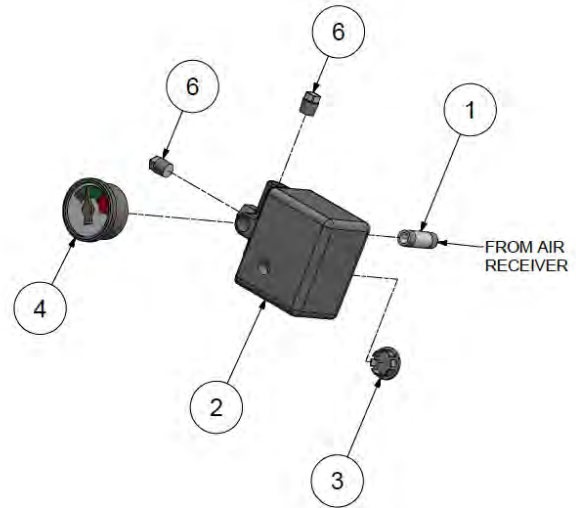

START/STOP CONTROL, NEMA 1

401CAD4052
403CAD4052

Item	Part Number	Description	Qty
1	M1016B	PIPE NIPPLE, 1.5"	2
2	P14205A	SWITCH,PRESSURE,95-125 (125 psi discharge)	2
2	P14202A	SWITCH,PRESSURE,140-175 (175 psi discharge)	2
3	M2352	KNOCKOUT HOLE PLUG	2
4	M519C	PRESSURE GAUGE	1
5	M2843	PRESSURE RELIEF VALVE, 200#	1
6	64AA5	PIPE PLUG	4

START/STOP CONTROL, NEMA 4

405CAD4052

Item	Part Number	Description	Qty
1	M1016B	PIPE NIPPLE, 1.5"	2
2	P07333A	SWITCH,PRESSURE,N4 (125 or 175 psi discharge)	2
4	M519C	PRESSURE GAUGE	1
5	M2843	PRESSURE RELIEF VALVE, 200#	1
-	M1003B (not shown)	PIPE TEE	2

Control Group – Duplex Dual Control (optional)

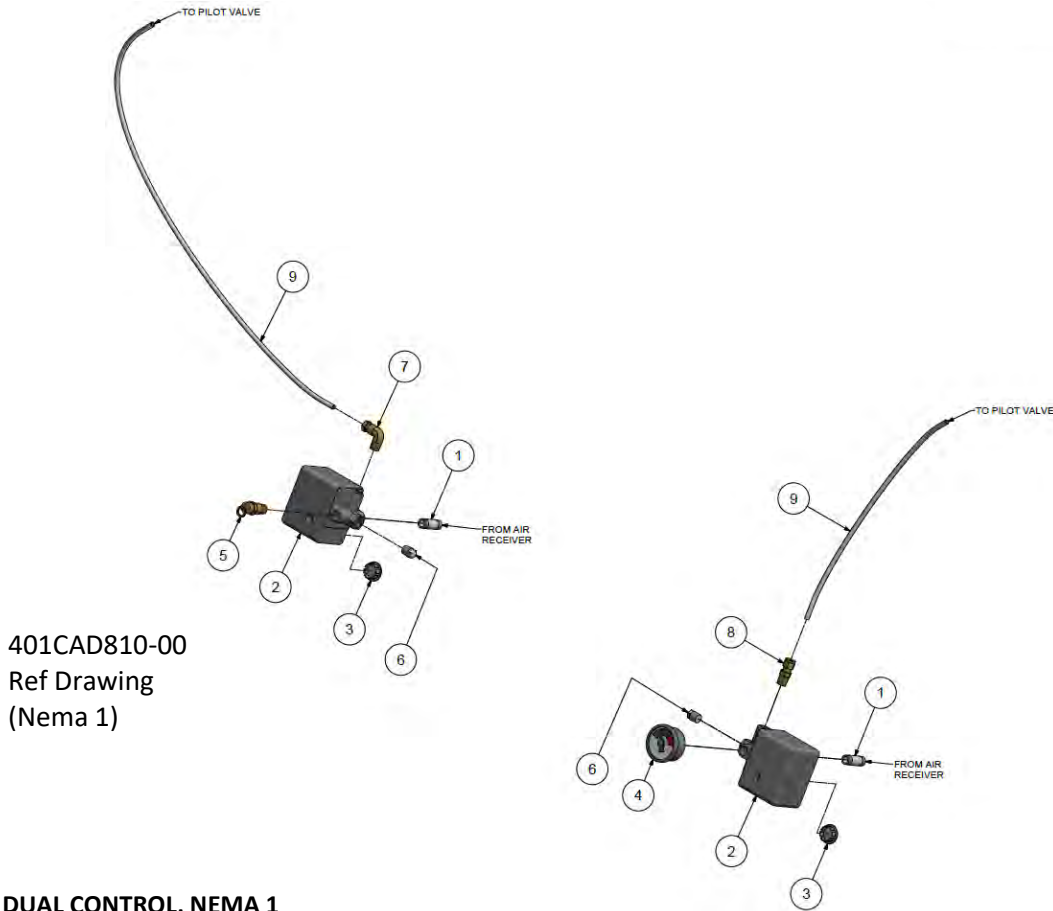

401CAD810-00
Ref Drawing
(Nema 1)

407CAD4052
411CAD4052

DUAL CONTROL, NEMA 1

Item	Part Number	Description	Qty
1	M1016B	NIPPLE	2
2	P14205A	SWITCH,PRESSURE,95-125 (125 psi discharge)	2
2	P14202A	SWITCH,PRESSURE,140-175 (175 psi discharge)	2
3	M2352	KNOCKOUT HOLE PLUG 1/2	2
4	M519C	PRESSURE GAUGE	1
5	M2843	PRESSURE RELIEF VALVE, 200#	1
6	64AA5	PIPE PLUG	2
7	86A40	COMPRESSION FITTING, ELBOW	1
8	M2862	COMPRESSION FITTING, STRAIGHT	1
9	P08084A	TUBING,PLASTIC,1/4OD	4 ft

409CAD4052
413CAD4052

DUAL CONTROL, NEMA 4

Item	Part Number	Description	Qty
1	M1016B	NIPPLE	2
-	M1003B (not shown)	PIPE TEE	2
-	64K1 (not shown)	PIPE CROSS	2
2	P07333A	SWITCH,PRESSURE,N4 (125 or 175 psi discharge)	2
4	M519C	PRESSURE GAUGE	1
5	M2843	PRESSURE RELIEF VALVE, 200#	1
7	86A40	COMPRESSION FITTING, ELBOW	1
8	M2862	COMPRESSION FITTING, STRAIGHT	1
9	P08084A	PLASTIC TUBING	4 ft

Power Transmission

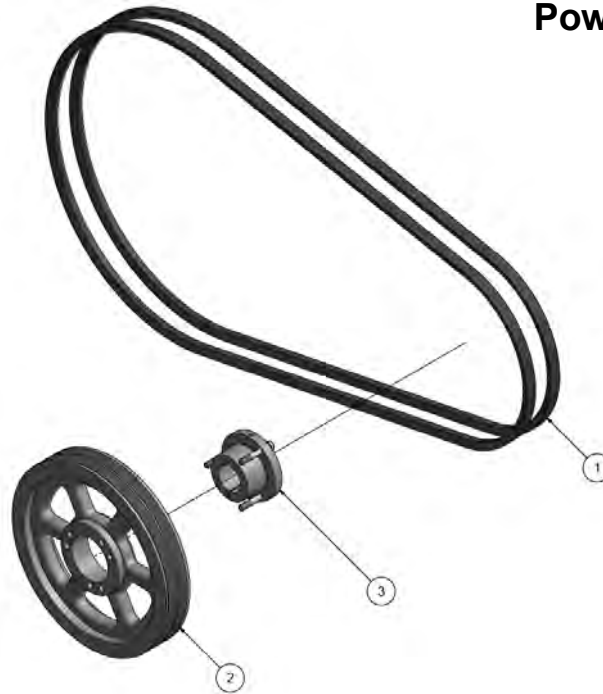

414CAS810-00
Ref Drawing

TRANSMISSION GROUP (R70,125PSI,20HP) Z2847

Item	Part Number	Description	Qty
1	B100	V BELT	3
2	P05345A	PULLEY,8.95OD,3GR,A/B	1
3	P05622A	BUSHING,PULLEY,SK,1-5/8	1

TRANSMISSION GROUP (R70,175PSI,20HP) Z2848

Item	Part Number	Description	Qty
1	B100	V BELT	3
2	P05634A	PULLEY,8.35OD,3GR,A/B	1
3	P05622A	BUSHING,PULLEY,SK,1-5/8	1

TRANSMISSION GROUP (R70,125PSI,25HP) Z2849

Item	Part Number	Description	Qty
1	B103	V BELT	3
2	P03710A	PULLEY,11.4OD,3GR,A/B	1
3	P05621A	BUSHING,PULLEY,SK,1-7/8	1

TRANSMISSION GROUP (R70,175PSI,25HP) Z2850

Item	Part Number	Description	Qty
1	B100	V BELT	3
2	P14238A	PULLEY,9.75OD,SK,3GR,A/B	1
3	P05621A	BUSHING,PULLEY,SK,1-7/8	1

TRANSMISSION GROUP (R70,125/175PSI,30HP) Z6485

Item	Part Number	Description	Qty
1	B103	V BELT	3
2	P03710A	PULLEY,11.4OD,3GR,A/B	1
3	P05621A	BUSHING,PULLEY,SK,1-7/8	1

Belt Guard – Standard

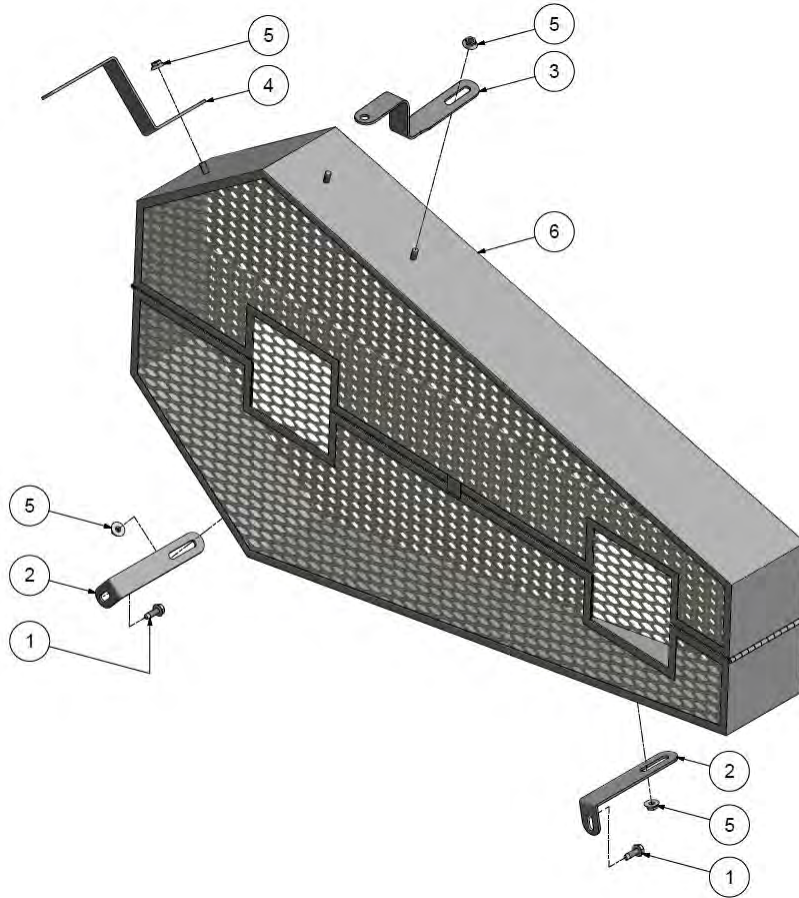

443CAS810-00
Ref Drawing

BELTGUARD - STANDARD

Z3723

Item	Part Number	Description	Qty
1	M1454	SCREW	2
2	M1535	BRACKET	2
3	M1536	BRACKET	1
4	M1594	BRACKET	1
5	M3485	NUT	4
6	P05620D	BELTGUARD	1

Belt Guard – with Aftercooler (optional)

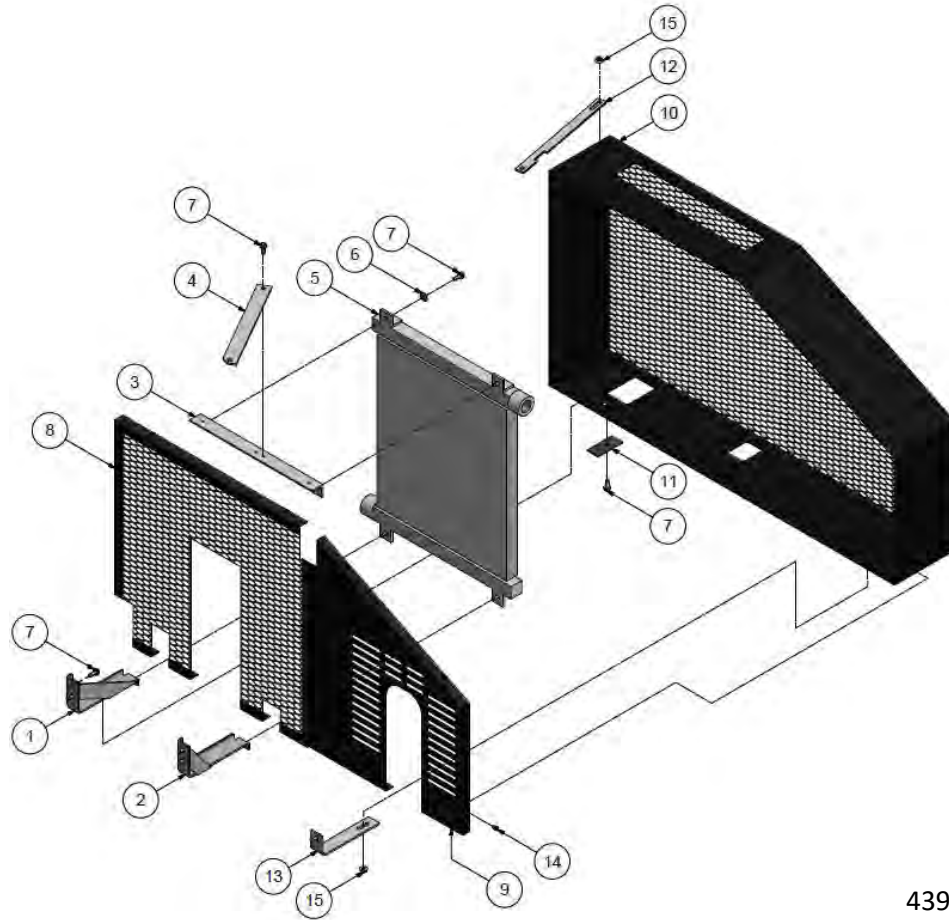

439CAS810-00
Ref Drawing

BELTGUARD - WITH AFTERCOOLER

402CAS4029

Item	Part Number	Description	Qty
1	P09960B	BRACKET	1
2	P09961B	BRACKET	1
3	P09962B	BRACKET	1
4	P10037A	BRACKET	1
5	P09954A	AFTERCOOLER	1
6	M3056	WASHER	4
7	M1454	SCREW	11
8	P09971C	BELTGUARD, BACK-PUMP END	1
9	P09972C	BELTGUARD, BACK-MOTOR END	1
10	P09973C	BELTGUARD, FRONT	1
11	M1368	PLATE	1
12	P10036A	BRACKET	1
13	P04567A	BRACKET	1
14	M1683	SCREW	14
15	M3485	NUT	2
16	P04365A	TRIM (NOT SHOWN)	4 FT

Discharge Piping – Simplex Horizontal, Standard

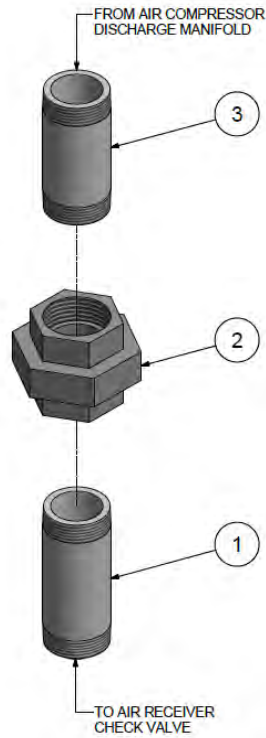

445CAS810-00
Ref Drawing

DISCHARGE PIPING - 120/240GL HORIZONTAL, STANDARD

410CAS4022

1	M1543	PIPE NIPPLE	1
2	M1919	PIPE UNION	1
3	M2222	PIPE NIPPLE	1

Discharge Piping – Simplex Horizontal, with Aftercooler (optional)

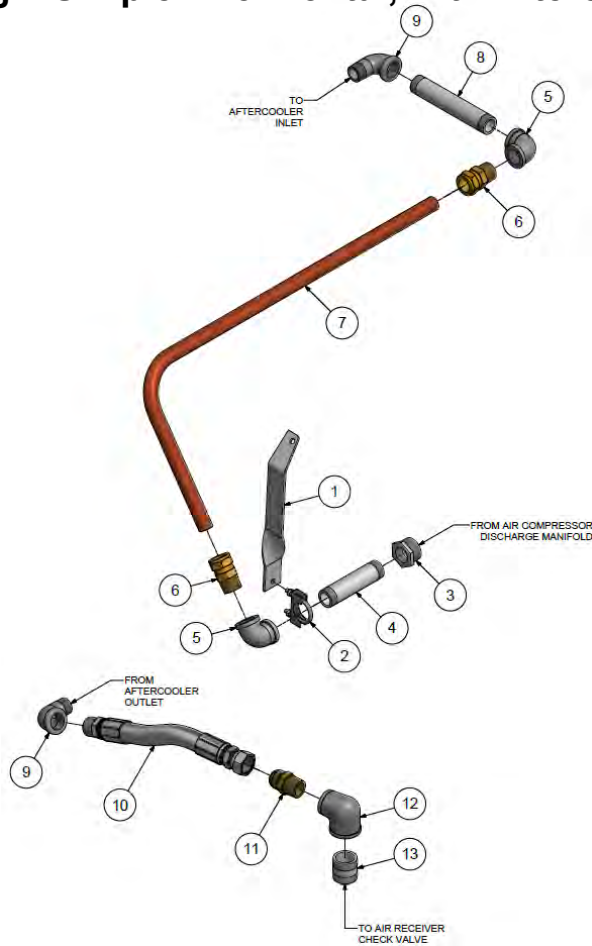

446CAS810-00
Ref Drawing

DISCHARGE PIPING – 120GL/240GL/BASE HORIZONTAL, AFTERCOOLER

404CAS4022
428CAS4022

1	P10038A	BRACKET,PIPING SUPPORT	1
2	P07556A	CLAMP	1
3	M954B	BUSHING	1
4	M2128	PIPE NIPPLE	1
5	M975B	PIPE ELBOW	2
6	P03591A	COMPRESSION FITTING, STRAIGHT	2
7	P12491A	DISCHARGE TUBE	1
8	M2305	PIPE NIPPLE	1
9	M983B	PIPE ELBOW	2
10	VP1019923	HOSE ASSEMBLY (TANK MOUNT ONLY)	1
11	P04300A	HOSE ADAPTER (TANK MOUNT ONLY)	1
12	M1999	PIPE ELBOW (TANK MOUNT ONLY)	1
13	M1039B	PIPE NIPPLE (TANK MOUNT ONLY)	1

Discharge Piping – Duplex Horizontal, Standard



409CAD810-00
Ref Drawing

DISCHARGE PIPING - 240GL HORIZONTAL, STANDARD

413CAD4022

Item	Part Number	Description	Qty
1	M983B	PIPE ELBOW	1
2	P03591A	COMPRESSION FITTING, STRAIGHT	1
3	CQM2475	DISCHARGE TUBE	1
4	M954B	BUSHING	1

Discharge Piping – Duplex Horizontal, with Aftercooler (optional)

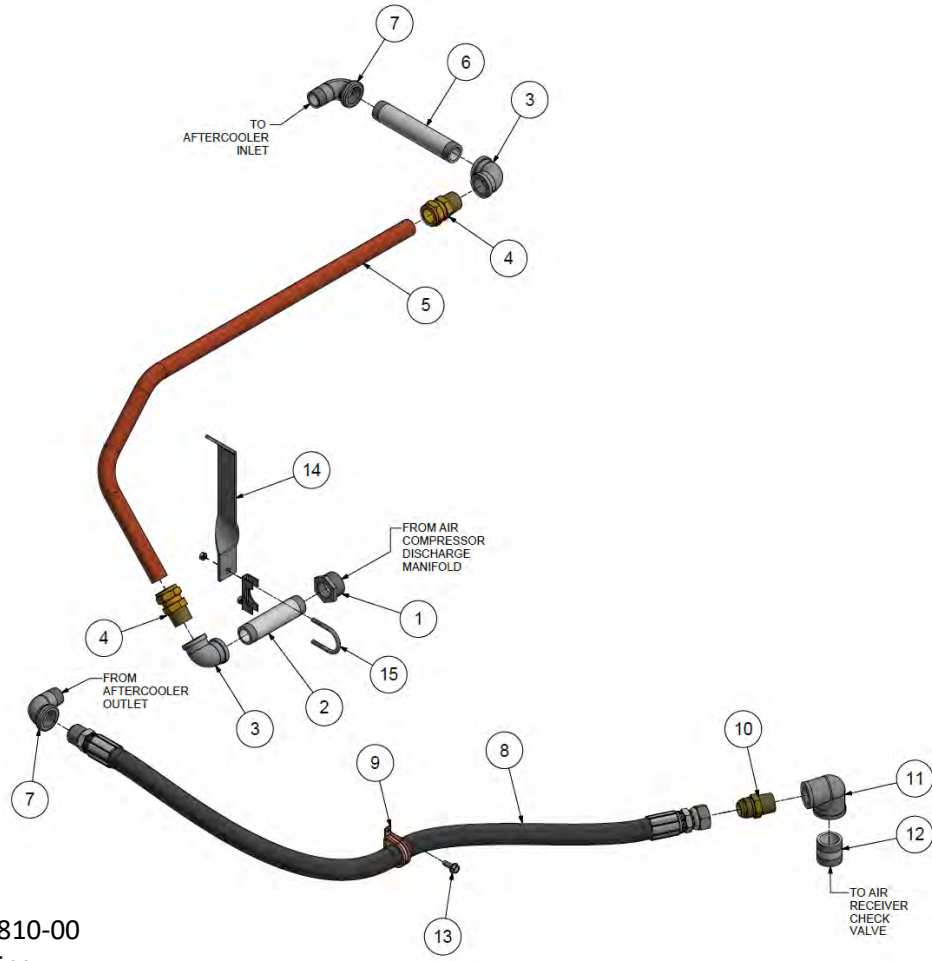

410CADS810-00
Ref Drawing

DISCHARGE ASSEMBLY IS SAME FOR BOTH SIDES

DISCHARGE PIPING - 240GL HORIZONTAL, AFTERCOOLER

414CAD4022

Item	Part Number	Description	Qty
1	M954B	BUSHING	1
2	M2128	PIPE NIPPLE	1
3	M975B	PIPE ELBOW	2
4	P03591A	COMPRESSION FITTING, STRAIGHT	2
5	P12491A	DISCHARGE TUBE	1
6	M2305	PIPE NIPPLE	1
7	M983B	PIPE ELBOW	2
8	CQZ12915	HOSE ASSEMBLY	1
9	P08874A	CLAMP	1
10	29Z214	ADAPTER	1
11	M1999	PIPE ELBOW	1
12	M1039B	PIPE NIPPLE	1
13	M1454	SCREW	1
14	P10038A	BRACKET	1
15	P07556A	CLAMP	1

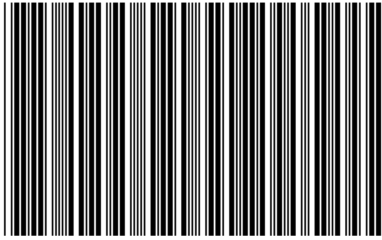

* C Q F 3 4 5 7 V E R O 2 *

CHAMPION

For additional information, contact your local representative or visit:
www.championpneumatic.com/contactus.aspx

©2019 Gardner Denver, Inc. Printed in U.S.A.



Please recycle after use.